

HEKO

VARICON

2008/2009

Electronic version - .pdf

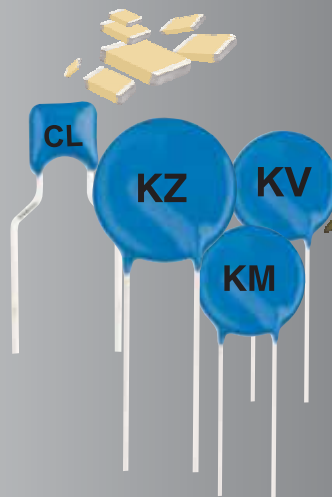

Capacitors

SMD and THD
Ceramic Capacitors

...not the biggest, simply the best!

Terminology and General Information - DISC CAPACITORS

Term	Symbol	Definition					
AC Capacitor		A capacitor designed essentially for application with a power - frequency alternating voltage					
RFI Suppression Capacitor		A capacitor used for the reduction of electromagnetic interference caused by electrical or electronic apparatus or other sources					
Capacitor of Class X		A capacitor suitable for use in situations where failure of the capacitor would not lead to danger of electric shock.					
Capacitor of Class Y		A capacitor suitable for use in situations where failure of the capacitor could lead to danger of electric shock.					
Rated AC Voltage	V_{rms}	AC operating voltage of rated frequency, which may be applied continuously to the terminations of a capacitor at any temperature between the lower and the upper category temperature					
Rated DC Voltage	V_r	DC operating voltage which may be applied continuously to the terminations of a capacitor at any temperature between the lower and the upper category temperature					
Impulse Voltage		An impulse voltage is an aperiodic transient voltage of a defined waveform as described in IEC 60-1					
Measuring and Testing Conditions	C and $\tan \delta$	1 kHz \pm 20 %, at max . 1,0 V_{rms} , 20-25 °C, 50-70 % RH					
	IR - Insulation resistance	500 V \pm 50 V, 60 s \pm 5 s, 20-25 °C, 50-70 % RH					
	V_t Voltage Proof of Dielectric Strength	Class X1 - 2 V_{rms} + 1500 V~ (min. 2000 V~), 50 Hz, 2s, 20-25 °C, 50-70 % RH					
		Class Y2 - 2 V_{rms} + 1500 V~ (min. 2000 V~), 50 Hz, 2 s, 20-25 °C, 50-70 % RH					
		Class Y1 - 4000 V~, 50 Hz, 2 s, 20-25 °C, 50-70 % RH					
Ceramic Type Designation	2E3 / 2F3	Ceramic Type Code : 2 (High Dielectric Constant Ceramics)					
		Capacitance Change Code : capacitance change relative to 20 °C capacitance value over the entire temperature range : E : +20/-56 % without AC voltage and +22/-70 % with AC voltage F : +30/-80 % without AC voltage and +30/-90 % with AC voltage					
		Temperature Range Code: 3 : -40/85 °C 4 : -25 /85 °C					
Application and Testing Class		Application Class according to DIN 40 040	Climatic Category according to DIN 40045	Humidity Stress			
		HPF GPF	-25/85/21 -40/85/21	Annual average < 75 %	for 30 days per year continuously 95%	for 60 days per year continuously -	on the remaining days occasionally 85%
Ageing Constant	k	<p>Following the final heat treatment all Type 2 ceramic capacitors reduce their capacitance value according to logarithmic law due to their special crystalline structure. This change is called ageing. If the capacitor is heated, for example during soldering, the capacitance value increases to higher value and the aging process begins again. The level of de-ageing depends on temperature and duration of the heat - for example an almost complete de-ageing is achieved at 150°C in one hour. These conditions are also the basis for reference measurements for any testings.</p> <p>Ageing constant is defined as capacitance change per time decade. Ageing constant differs for various types of ceramics. For 2E3 and 2F3 ceramics used for RFI suppression and safety capacitors ageing constant ranges from -3 to -5 %.</p>					

Contents :	Page
Terminology & General Information - Disk ceramic Capacitors	2 and 4
KM Series – RFI Suppression Capacitors	5
Device Ratings and Characteristics	6
KZ Series – Safety Capacitors	7
Device Ratings and Characteristics	8
KV Series – High Voltage Capacitors	9
Device Ratings and Characteristics	10
Available Lead Style	11
Ordering Information & Marking - KM / KZ Series	12
Ordering Information & Marking - KM / KZ Series	13
Tape & Reel Specification - KM / KZ / KV Series	14
Packaging - KM / KZ / KV Series	15
Assembly recommendations for TH Components	16
C and CL Series - Multilayer Ceramic Capacitors	17
Dimensions, Marking and Ordering information	18
Device Ratings and Characteristics	19
Soldering Recommendations & Storage	28
Soldering Pad Configuration	31
Tape & Reel Specification SMD - C Series	32
Tape & Reel Specification THD (Leaded) - CL Series	33
Reliability Testing	35

Terminology and General Information - DISC CAPACITORS

<p>Reference Measurements</p>	<p>Due to ageing it is necessary to quote an age for reference measurements which can be related to the capacitance with the fixed tolerance. As defined in CECC 30700 this age is 1000 h. If the age of the capacitor is known, the capacitance for $t = 1000$ h can be calculated using known ageing constant :</p> $k = 100 (C_1 - C_2) / [C_1 \cdot \log(t_1/t_2)] \Rightarrow C_2 = C_1 \cdot [1 - k / (100 \cdot \log(t_1/t_2))]$ <p>where k is ageing constant in %, t_1, t_2 are measurement time points and C_1, C_2 capacitance values at time t_1 and t_2 respectively.</p> <p>It is important to de-age the capacitors before any stress testing, so that the changes as a result of the test are not affected by age. The following procedure should be used for any stress measurements (according to CECC 30700, appendix B) :</p> <ul style="list-style-type: none"> - de-ageing at 150 °C, 1 h - storage : 24 h at 20-25 °C, 50-70 % RH - initial measurements - stress test - de-ageing at 150 °C, 1 h - storage : 24 h at 20-25 °C, 50-70 % RH - final measurements 			
<p>Soldering Specifications</p>	<p>Conditions</p>	<p>Soldering Temperature</p>	<p>Soldering Time</p>	<p>Distance from Component Body</p>
	<p>Solderability</p>	<p>250 ± 5 °C</p>	<p>2 ± 0,5 s</p>	<p>> 2 mm</p>
	<p>Resistance to Soldering Heat</p>	<p>295 ± 5 °C</p>	<p>10 ± 1 s</p>	<p>> 5 mm</p>
<p>Climatic Category</p>	<p>LCT/UCT/DHD</p>	<p>UCT = The maximum surface temperature for which the capacitor has been designed to operate continuously LCT = The minimum surface temperature for which the capacitor has been designed to operate continuously DHD = Dump Heat Test Duration</p>		
<p>Storage</p>	<p>Solderability of leads is not affected by storage for 24 months, if storage temperature is 10-35 °C and relative humidity up to 60 %.</p>			
<p>Flammability</p>	<p>Active</p>	<p>The ability to burn with flame as a consequence of electrical loading. The minimum category of passive flammability is category C.</p>		
	<p>Passive</p>	<p>The ability of a capacitor to burn with flame as a consequence of application of an external source of heat.</p>		

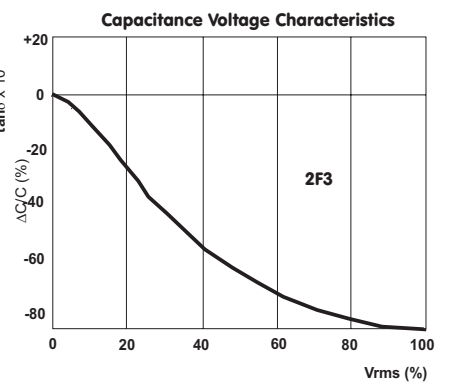
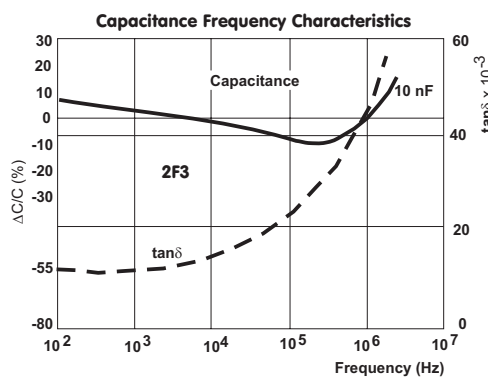
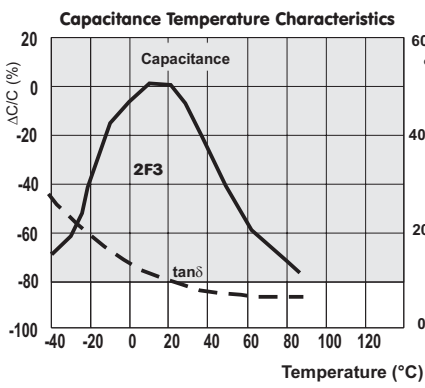
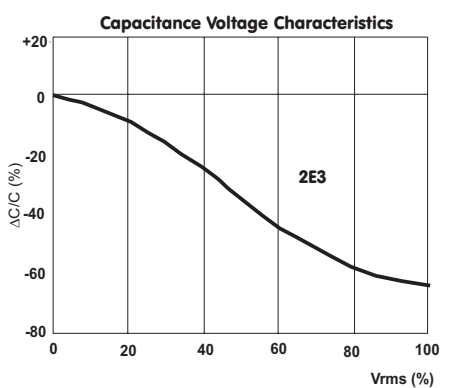
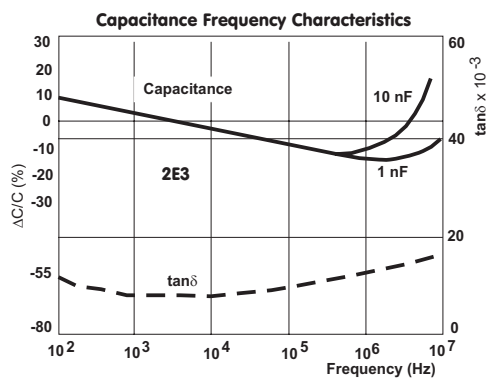
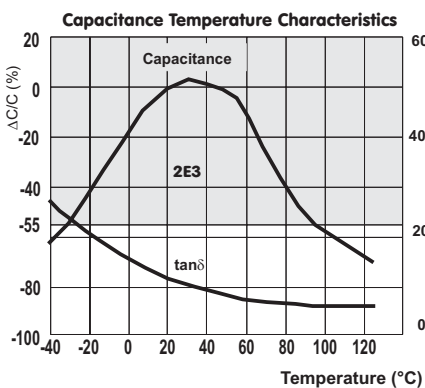

RADIO INTERFERENCE SUPPRESSION DISC CAPACITORS KM SERIES

Description

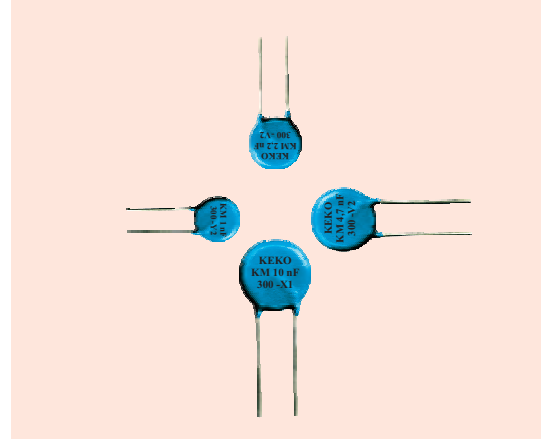

Radio interference suppression KM capacitors offered by KEKO VARICON cover a wide capacitance range from 1 nF to 22 nF, operating at rated AC voltages 300 V and at frequency of 50 Hz.

KEKO VARICON presently offers two branches of Type 2 KM capacitors : Class X1 and Class Y2. They are successfully used in radio interference suppression for home appliances.



Features

KM Y2

- Capacitance range 1 nF to 10 nF.
- Rated AC Voltage V_{rms} 300 V / 50 Hz.
- 9 Model sizes available 7 to 18 mm discs.
- Dielectric Temperature Characteristics : 2E3.
- Maximum operating temperature - +125 °C.
- Available with straight and crimped leads.
- Available in tape and reel for automatic pick and place.
-  File No. 5883.11-4670-0011/31WCJ F35/KIL for KM -Y2 capacitors according to standard EN 132400 and IEC 60384-14 for capacitance range from 1 nF to 10 nF for rated voltage of 300 V~.
-  UL1414 & CSA C22.2 Across-The-Line Applications File E163318 for **KM-Y2** for capacitance range from 1 nF to 10 nF for rated voltage of 300 V~ .
- Lead free components.

Absolute Maximum Ratings

	Units	KM Y2
Capacitance range (C)	nF	1 to 10
Capacitance Tolerance	%	M
Voltage Dependence		yes
Dissipation Factor tg δ		$\leq 25 \cdot 10^{-3}$
Rated AC Voltage Range (V_{rms}) at 50 Hz	V	300
Measuring Conditions		
AC Voltage	V	1 ± 0.2
Frequency	kHz	$1 \pm 20 \%$
Test AC Voltage	kV	2.2 for 2 s
Test AC Voltage to Earth	kV	2
Insulation Resistance IR at 500 V	G Ω	≥ 6
AC Voltage Proof of Coating	kV	2 for 60 s
Operating Ambient Temperature	°C	-40 to +125
Climatic Category	4	40/125/21 - GPF
Comply with standards		IEC 384/14, UL1414 CSA C22.2 No. 1-M1981

Device Ratings and Characteristics

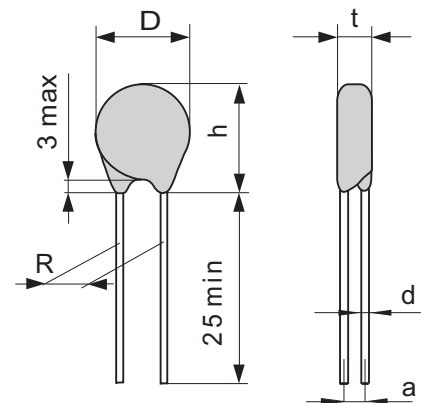

Radio Interference Suppression Disc Capacitors - Class Y2

Type	C	$\tan \delta$	V_{rms}	D	t	R	d	h	a
	nF	10E-3	V	max mm	max mm	± 1 mm	$\pm 0,05$ mm	max mm	± 1 mm
KM 1.0 nF M 2E3 300 Y2	1,0	25	300	7	4,5	5,0	0,6	10	1,4
KM 1.5 nF M 2E3 300 Y2	1,5	25	300	8	4,5	5,0	0,6	11	1,4
KM 1.8 nF M 2E3 300 Y2	1,8	25	300	8	4,5	5,0	0,6	11	1,4
KM 2.2 nF M 2E3 300 Y2	2,2	25	300	9	4,5	5,0	0,6	12	1,4
KM 2.5 nF M 2E3 300 Y2	2,5	25	300	9	4,5	5,0	0,6	12	1,4
KM 2.7 nF M 2E3 300 Y2	2,7	25	300	9	4,5	5,0	0,6	12	1,4
KM 3.3 nF M 2E3 300 Y2	3,3	25	300	10	4,5	7,5	0,8	13	1,4
KM 3.9 nF M 2E3 300 Y2	3,9	25	300	11	4,5	7,5	0,8	14	1,4
KM 4.7 nF M 2E3 300 Y2	4,7	25	300	11	4,5	7,5	0,8	14	1,4
KM 5.0 nF M 2E3 300 Y2	5,0	25	300	12	4,5	7,5	0,8	15	1,4
KM 5.6 nF M 2E3 300 Y2	5,6	25	300	14	4,5	7,5	0,8	17	1,6
KM 6.8 nF M 2E3 300 Y2	6,8	25	300	14	4,5	7,5	0,8	17	1,6
KM 8.2 nF M 2E3 300 Y2	8,2	25	300	16	4,5	7,5	0,8	19	1,6
KM 10 nF M 2E3 300 Y2	10,0	25	300	18	4,5	7,5	0,8	21	1,6

Impedance Frequency Characteristics

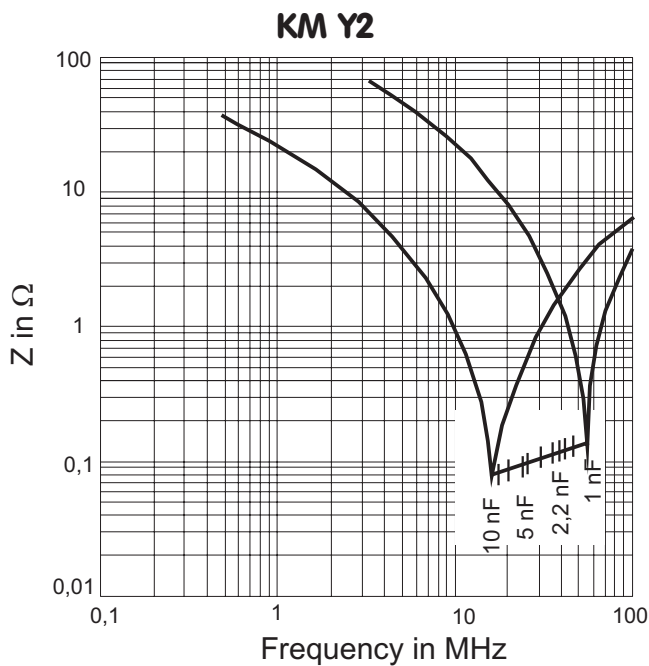

SAFETY CERAMIC DISC CAPACITORS KZ SERIES

Description

Safety ceramic disc KZ capacitors are intended for galvanic separation of mains and conductive parts that might be touched, i.e. antenna inputs in radio and TV sets. They are ideal for line by-pass, antenna coupling and across-the-line applications, especially for the circuits exposed to danger of electric shock. These capacitors meet safety rules applicable to electronic apparatus and associated fittings for domestic or similar general use, connected to mains according to EN 132 400.

KZ capacitors offered by KEKO VARICON cover capacitance range from 330 pF to 4700 pF, operating at AC rated voltages 300 V for Y2 Class and 500 V for Y1 and X1 Classes at frequency of 50 Hz.

KEKO VARICON presently offers two groups of Type 2 KZ capacitors : group KZL - Class Y2 and Class X1 which can withstand test voltage of 2.5 kV AC and group KZH - Class Y1 and Class X1 which can withstand test voltage of 4kVAC.

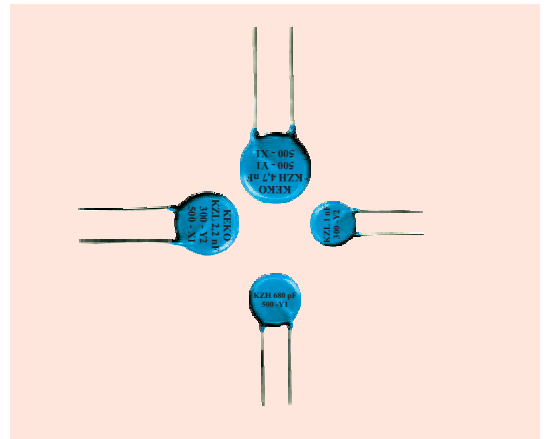

Features

- Capacitance range 330 pF to 4700 pF.
- Rated AC Voltage V_{rms}500 V (X1), 300 V(Y2) / 50 Hz.
- 7 Model sizes available 6 to 14 mm discs.
- Dielectric Temperature Characteristics : 2E3.
- Available with straight and crimped leads.
- Available in tape and reel for automatic pick and place.

- File No. 5883.11-4670-0011/31A4Y F35/KIL, Mark Licence No. 124251, according to standard EN 132 400 / IEC 60384-14 for KZL X1/Y2 capacitors for capacitance from 330 pF to 4700 pF for rated voltage 300/500 VAC.
- File No. 5883.11-4620-1010/A11, according to standard DIN VDE 0560-2/05.70 for capacitance range from 33 pF to 4700 pF for rated voltage 400 VAC.
- UL1414 & CSA C22.2 Antenna Coupling, Across-The-Line and Line-By-Pass Applications File E163318 for KZL-Y2/X1 for capacitance range from 330 pF to 4700 pF for rated voltage of 300/500 V~
- *Lead free components.*

KZH X1/Y1

- Capacitance range 330 pF to 4700 pF.
- Rated AC Voltage V_{rms} 500 V / 50 Hz.
- 8 Model sizes available 6 to 16 mm discs.
- Dielectric Temperature Characteristics : 2E3.

Absolute Maximum Ratings

	KZL X1	KZL Y2	KZH X1/Y1
Units	2E3		
Capacitance range (C)	pF 330 to 4700		
Capacitance Tolerance	%		
Voltage Dependence	yes		
Dissipation Factor tg δ	$\leq 25 \cdot 10^{-3}$		$\leq 25 \cdot 10^{-3}$
Rated AC Voltage Range (V_{rms}) at 50 Hz	500	300	500
Measuring Conditions			
AC Voltage	V 1 ± 0.2		
Frequency	kHz $1 \pm 20 \%$		
Test AC Voltage	kV 2.5 for 2 s		4 for 2 s
Test AC Voltage to Earth	kV 2.5		4
Insulation Resistance IR at 500 V	G Ω ≥ 6		≥ 10
AC Voltage Proof of Coating	kV 2.5 for 60 s		4 for 60s
Operating Ambient Temperature	$^{\circ}\text{C}$ -40 to +125		
Climatic Category	40/125/21 - GPF		
Comply with standards	IEC 384-14, UL1414, CSA C 22.2 No. 1-M1994		

Device Ratings and Characteristics

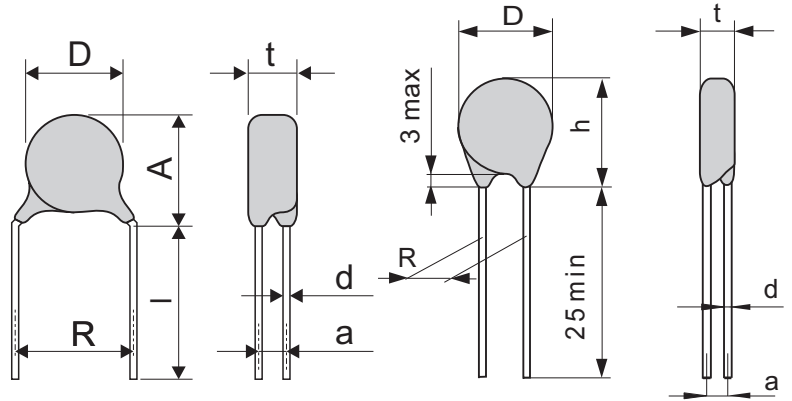

Safety Disc Capacitors - KZL Class Y2, X1

Type	C pF	tan δ 10E-3	V _{rms} V	D max mm	t max mm	R ± 1 mm	d ± 0,05 mm	h/A max mm	a ± 1 mm
KZL 330 pF M 2E3 300/500 Y2/X1	330	25	300/500	6	5	7,5	0,6	9	1,9
KZL 470 pF M 2E3 300/500 Y2/X1	470	25	300/500	6	5	7,5	0,6	9	1,9
KZL 680 pF M 2E3 300/500 Y2/X1	680	25	300/500	7	5	7,5	0,6	10	1,9
KZL 1.0 nF M 2E3 300/500 Y2/X1	1000	25	300/500	8	5	7,5	0,8	11	2,1
KZL 1.5 nF M 2E3 300/500 Y2/X1	1500	25	300/500	9	5	7,5	0,8	12	2,1
KZL 2.2 nF M 2E3 300/500 Y2/X1	2200	25	300/500	10	5	7,5	0,8	13	2,1
KZL 3.3 nF M 2E3 300/500 Y2/X1	3300	25	300/500	12	5	7,5	0,8	15	2,1
KZL 3.9 nF M 2E3 300/500 Y2/X1	3900	25	300/500	12	5	7,5	0,8	15	2,1
KZL 4.7 nF M 2E3 300/500 Y2/X1	4700	25	300/500	14	5	7,5	0,8	17	2,1

Safety Disc Capacitors - KZH Class Y1, X1

Type	C pF	tan δ 10E-3	V _{rms} V	D max mm	t max mm	R ± 1 mm	d ± 0,05 mm	h/A max mm	a ± 1 mm
KZH 330 pF M 2E3 500 Y1/X1	330	25	500	7	6,5	10	0,8	10	3,1
KZH 470 pF M 2E3 500 Y1/X1	470	25	500	7	6,5	10	0,8	10	3,1
KZH 680 pF M 2E3 500 Y1/X1	680	25	500	7	6,5	10	0,8	10	3,1
KZH 1.0 nF M 2E3 500 Y1/X1	1000	25	500	8	6,5	10	0,8	11	3,1
KZH 1.5 nF M 2E3 500 Y1/X1	1500	25	500	9	6,5	10	0,8	12	3,1
KZH 2.2 nF M 2E3 500 Y1/X1	2200	25	500	12	6,5	10	0,8	14	3,1
KZH 3.3 nF M 2E3 500 Y1/X1	3300	25	500	12	6,5	10	0,8	15	3,1
KZH 3.9 nF M 2E3 500 Y1/X1	3900	25	500	14	6,5	10	0,8	17	3,1
KZH 4.7 nF M 2E3 500 Y1/X1	4700	25	500	16	6,5	10	0,8	19	3,1

Impedance Frequency Characteristics

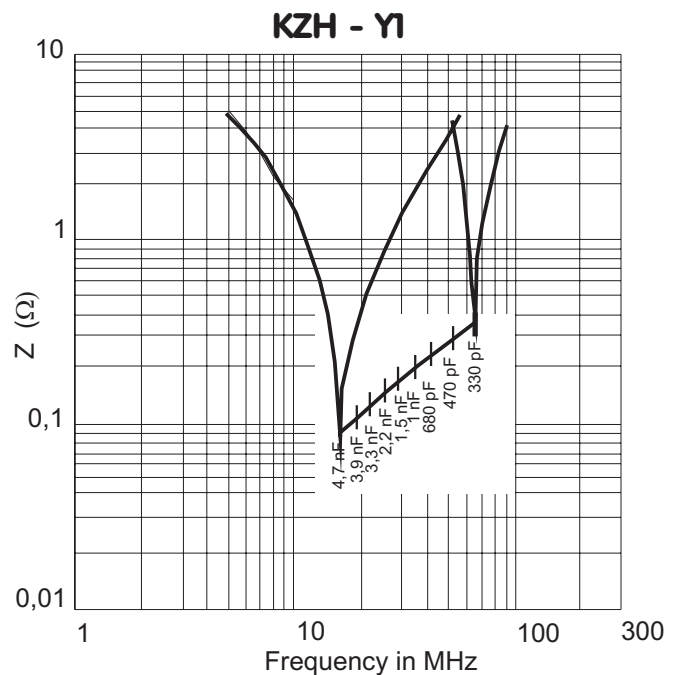
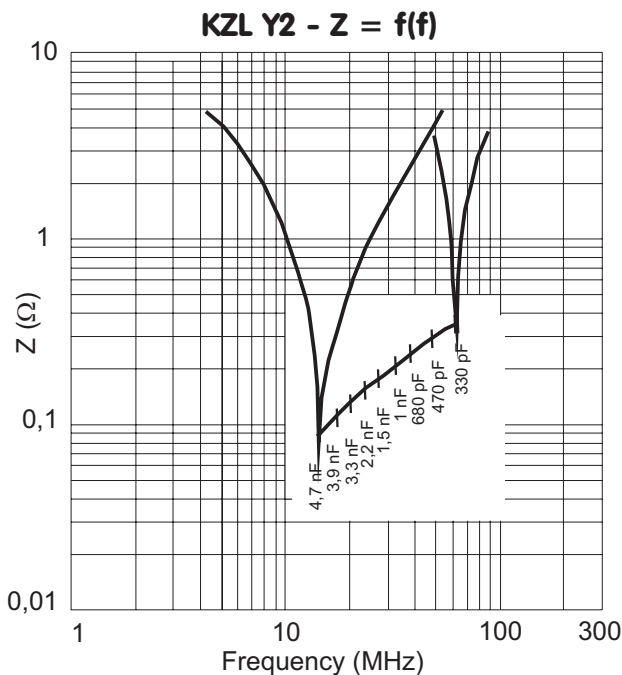

HIGH VOLTAGE CERAMIC DISC CAPACITORS KV SERIES

Description

High voltage ceramic Type 2 disc capacitors cover capacitance range from 330 pF to 10 nF operating at voltages from 1 to 6 kVDC.

These capacitors utilize high dielectric constant ($K > 8000$) ferroelectric formulations based on barium titanate. They exhibit markedly nonlinear temperature characteristics, significant dependence on voltage and frequency and predictable decay of capacitance with time.

Such capacitors are suited for by-pass, coupling and filtering applications, where Q, high insulation resistance and stability of capacitance characteristics are not of major importance.

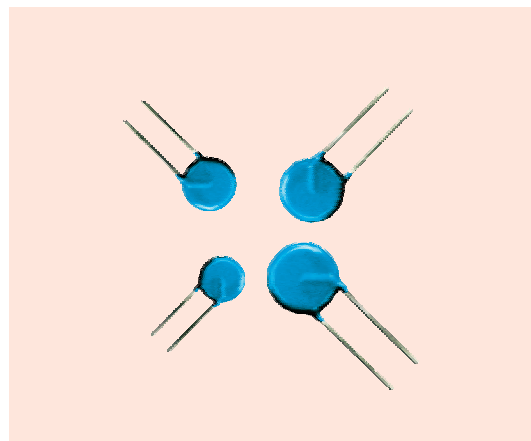

Features

- *Capacitance range330 pF to 10 nF.*
- *Rated DC Voltage V_n 1 - 6 kV.*
- *9 Model sizes available7 to 18 mm discs.*
- *Dielectric Temperature Characteristics : 2E4.*
- *Maximum operating temperature - +85 °C.*
- *Available with straight and crimped leads.*
- *1 and 2 kV capacitors available in tape and reel for automatic pick and place.*
- *Lead free components.*

Absolute Maximum Ratings

	Units	Value
Capacitance range (C)	nF	0,33 to 10
Capacitance Tolerance	%	M
Voltage Dependence		yes
Dissipation Factor $tg \delta$		$\leq 25 \cdot 10^{-3}$
Rated DC Voltage Range (V_n)	kV	1 - 6
Measuring Conditions		
AC Voltage	V	1 ± 0.2
Frequency	kHz	$1 \pm 20 \%$
Test DC Voltage	kV	$1,5 V_n + 500$
Test AC Voltage to Earth	kV	1,5
Insulation Resistance IR at 500 V	GΩ	> 4
Operating Ambient Temperature	°C	-25 to +85
Climatic Category	4	25 /85/21-GPF
Comply with standards		IEC 384-9

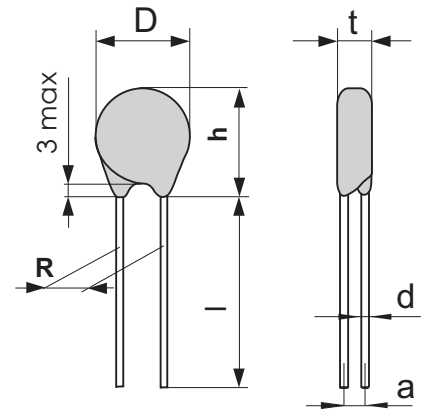
Device Ratings and Characteristics

High Voltage Ceramic Disc Capacitors KV

Type	C nF	tan δ 10E-3	Vn kV	D max mm	t max mm	R ± 1 mm	d $\pm 0,05$ mm	h max mm	a ± 1 mm
KV 330 pF M 2E4 2 kV D6 R5	0,33	25	2	6	4,5	5,0	0,6	10	1,4
KV 470pF M 2E4 2 kV D6 R5	0,47			6	4,5	5,0	0,6	10	1,4
KV 680 pF M 2E4 2 kV D6 R5	0,68			6	4,5	5,0	0,6	10	1,4
KV 820 pF M 2E4 2 kV D7 R5	0,82			7	4,5	5,0	0,6	10	1,4
KV 1 nF M 2E4 2 kV D7 R5	1,0			7	4,5	5,0	0,6	10	1,4
KV 1.5 nF M 2E4 2 kV D8 R5	1,5			8	4,5	5,0	0,6	11	1,4
KV 1.8 nF M 2E4 2 kV D8 R5	1,8			8	4,5	5,0	0,6	11	1,4
KV 2.2 nF M 2E4 2 kV D9 R5	2,2			9	4,5	5,0	0,6	12	1,4
KV 2.5 nF M 2E4 2 kV D9 R5	2,5			9	4,5	5,0	0,6	12	1,4
KV 3.3 nF M 2E4 2 kV D10R7.5	3,3			10	4,5	7,5	0,8	13	1,4
KV 3.9 nF M 2E4 2 kV D11 R7.5	3,9			11	4,5	7,5	0,8	14	1,4
KV 4.7 nF M 2E4 2 kV D11 R7.5	4,7			11	4,5	7,5	0,8	14	1,4
KV 5.0 nF M 2E4 2 kV D12 R7.5	5,0			12	4,5	7,5	0,8	15	1,4
KV 6.8 nF M 2E4 2 kV D14 R7.5	6,8			14	4,5	7,5	0,8	17	1,6
KV 8.2 nF M 2E4 2 kV D16 R7.5	8,2			16	4,5	7,5	0,8	19	1,6
KV 10 nF M 2E4 2 kV D18 R7.5	10,0			18	4,5	7,5	0,8	21	1,6
KV 330 pF M 2E4 4 kV D6 R5	0,33	25	4	6	5	5	0,6	10	1,9
KV 470 pF M 2E4 4 kV D6 R5	0,47			6	5	5	0,6	10	1,9
KV 680 pF M 2E4 4 kV D7 R5	0,68			7	5	5	0,6	10	1,9
KV 820 pF M 2E4 4 kV D8 R5	0,82			8	5	5	0,6	11	2,1
KV 1.0 nF M 2E4 4 kV D8 R5	1,0			8	5	5	0,6	11	2,1
KV 1.5 nF M 2E4 4 kV D9 R5	1,5			9	5	5	0,6	12	2,1
KV 1.8 nF M 2E4 4 kV D10 R7.5	1,8			10	5	7,5	0,8	13	2,1
KV 2.2 nF M 2E4 4 kV D10 R7.5	2,2			10	5	7,5	0,8	13	2,1
KV 2.5 nF M 2E4 4 kV D10 R7.5	2,5			11	5	7,5	0,8	14	2,1
KV 3.3 nF M 2E4 4 kV D12 R7.5	3,3			12	5	7,5	0,8	15	2,1
KV 3.9 nF M 2E4 4 kV D14 R7.5	3,9			14	5	7,5	0,8	17	2,1
KV 4.7 nF M 2E4 4 kV D14 R7.5	4,7			14	5	7,5	0,8	17	2,1
KV 330 pF M 2E4 6 kV D6 R5	0,33	25	6	7	6,5	5	0,6	10	3,1
KV 470 pF M 2E4 6 kV D6 R5	0,47			7	6,5	5	0,6	10	3,1
KV 680 pF M 2E4 6 kV D7 R5	0,68			7	6,5	5	0,6	10	3,1
KV 820 pF M 2E4 6 kV D8 R5	0,82			8	6,5	5	0,6	11	3,1
KV 1.0 nF M 2E4 6 kV D8 R5	1,0			8	6,5	5	0,6	11	3,1
KV 1.5 nF M 2E4 6 kV D9 R5	1,5			9	6,5	5	0,6	12	3,1
KV 1.8 nF M 2E4 6 kV D10 R7.5	1,8			10	6,5	7,5	0,8	13	3,1
KV 2.2 nF M 2E4 6 kV D10 R7.5	2,2			12	6,5	7,5	0,8	14	3,1
KV 2.5 nF M 2E4 6 kV D10 R7.5	2,5			12	6,5	7,5	0,8	14	3,1
KV 3.3 nF M 2E4 6 kV D12 R7.5	3,3			12	6,5	7,5	0,8	15	3,1
KV 3.9 nF M 2E4 6 kV D14 R7.5	3,9			14	6,5	7,5	0,8	17	3,1
KV 4.7 nF M 2E4 6 kV D16 R7.5	4,7			16	6,5	7,5	0,8	19	3,1

Lead Styles

Type	R (mm)	h (mm)	A (mm)	Version 1	Version 5
KM 1 nF Y2 KM 1,5...1,8 nF Y2 KM 2,2...2,5 nF Y2	5	10 11 12			
KZL 1 nF Y2 KZL 1,5 nF Y2 KM 3,3 nF Y2.....KZL 2,2 nF Y2 KM 4,7 nF Y2 KM 5 nF Y2...KZL 3,3...3,9 nF Y2 KM 6,8 nF Y2..... KZL 4,7 nF Y2 KM 8,2 nF Y2 KM 10 nF Y2	7,5	11 12 13 14 15 17 19 21			
KZL 330....470 pF Y2 KZL 680 pF Y2 KZH 330 pF Y1 KZH 470...680 pF Y1 KZH 1 nF Y1 KZH 1,5 nF Y1	7,5 7,5 10 10 10 10		9 10 9 10 11 12		
KZH 2,2 nF Y1 KZH 3,3 nF Y1 KZH 3,9 nF Y1 KZH 4,7 nF Y1	10	14 15 17 19			
KV 330 pF...1 nF 2 kV KV 330....680 pF 4 kV KV 330 pF...680 pF 6 kV KV 1,5...1,8 nF 2 kV KV 820 pF...1 nF 4 kV KV 820 pF...1 nF 6 kV KV 2,2...2,5 nF 2 kV KV 1,5 nF 4 kV KV 1,5 nF 6 kV	5	10 10 10 11 11 11 12 12 12	15 15 15 16 16 16 17 17 17		
KV 3,3 nF 2 kV KV 1,8...2,2 nF 4 kV KV 1,8 nF 6 kV KV 3,9....4,7 nF 2 kV KV 2,5 nF 4 kV KV 2,2...2,5 nF 6 kV KV 5 nF 2 kV KV 3,3 nF 4 kV KV 3,3 nF 6 kV KV 6,8 nF 2 kV KV 3,9...4,7 nF 4 kV KV 3,9 nF 6 kV KV 8,2 nF 2 kV KV 4,7 nF 6 kV KV 10 nF 2 kV	7,5	13 13 13 14 14 14 15 15 15 17 17 17 19 19 21			

Ordering Information

KZH - Series Name : KM, KZL, KZH
4,7nF - Capacitance value
M - Capacitance Tolerance : K = $\pm 10\%$, M = $\pm 20\%$
2E3 - Ceramic type Designation
500 - Rated AC Voltage : 300, 500 V
Y1 - Capacitor Class : X1, Y2, Y1
R - Packaging : R = Reel, A = Ammo Pack, B = Bulk
L1 - Lead Style : 1 = straight, 5 = crimped
YY - Special requirements

KZH 4,7nF M 2E3 500 Y1/X1 R L1 YY

Capacitor Marking

KM Series
For Model Size < 9 mm
 KM 1n0
 300~Y2
 KM - Series Name
 1n0 - Capacitance Value = 1 nF
 300~ - Rated Voltage
 Y2 - Capacitor Class

For Model Size = 9 mm
 KEKO
 KM 2n2
 300~Y2
 KEKO - Tradename
 KM - Series Name
 2n2 - Capacitance Value = 2,2 nF
 300~ - Rated Voltage
 Y2 - Capacitor Class

For Model Size > 9 mm
 KEKO
 KM 10n0
 300~Y2
 xx
 KEKO - Tradename
 KM - Series Name
 10n0 - Capacitance Value = 10 nF
 300~ - Rated Voltage
 Y2 - Capacitor Class
 xx - Approvals

KZL Series
For Model Size < 9 mm
 KZL 1n0
 300~Y2
 KZL - Series Name
 1n0 - Capacitance Value = 1 nF
 300~ - Rated Voltage
 Y2 - Capacitor Class

For Model Size = 9 mm
 KEKO
 KZL 1n5
 300~Y2
 KEKO - Tradename
 KZL - Series Name
 1n5 - Capacitance Value = 1,5 nF
 300~ - Rated Voltage
 Y2 - Capacitor Class

For Model Size > 9 mm
 KEKO
 KZL 3n3
 500~X1
 xx
 KEKO - Tradename
 KZL - Series Name
 3n3 - Capacitance Value = 3,3 nF
 500~ - Rated Voltage
 X1 - Capacitor Class
 xx - Approvals

KZH Series
For Model Size < 9 mm
 KZH n47
 500~Y1/X1
 KZH - Series Name
 n47 - Capacitance Value = 470 pF
 500~ - Rated Voltage
 Y1/X1 - Capacitor Class

For Model Size = 9 mm
 KEKO
 KZH 1n5
 500~Y1/X1
 KEKO - Tradename
 KZH - Series Name
 1n5 - Capacitance Value = 1,5 nF
 500~ - Rated Voltage
 Y1/X1 - Capacitor Class

For Model Size > 9 mm
 KEKO
 KZH 4n7
 500~Y1/X1
 xx
 KEKO - Tradename
 KZH - Series Name
 4n7 - Capacitance Value = 4,7 nF
 500~ - Rated Voltage
 Y1/X1 - Capacitor Class
 xx - Approvals

Ordering Information

- KV** - Series Name : KV
- 4,7nF** - Capacitance value
- M** - Capacitance Tolerance : M = ± 20 %, K = ± 10 %
- 2E4** - Ceramic type Designation
- 2kV** - Rated DC Voltage : 1, 2, 3, 4, 5, 6 kV
- D11** - Capacitor Diameter
- R** - Packaging : R = Reel, A = Ammo Pack, B = Bulk
- L1** - Lead Style : 1 = straight, 5 = crimped
- YY** - Special requirements

KV 4,7nF M 2E4 2kV D11 R L1 YY

Capacitor Marking

2 kV
For Model Size < 9 mm
KV 1n0
1 kV

KV - Series Name
1n0 - Capacitance Value = 1 nF
1 kV - Rated Voltage

For Model Size = 9 mm

KEKO
KV 2n2
2 kV
KEKO - Tradename
KV - Series Name
2n2 - Capacitance Value = 2,2 nF
2 kV - Rated Voltage

For Model Size > 9 mm

KEKO
KV 10n0
2 kV
KEKO - Tradename
KV - Series Name
10n0 - Capacitance Value = 10 nF
2 kV - Rated Voltage

4 kV
For Model Size < 9 mm
KV 1n0
3 kV

KV - Series Name
1n0 - Capacitance Value = 1 nF
3 kV - Rated Voltage

For Model Size = 9 mm

KEKO
KV 1n5
4 kV
KEKO - Tradename
KV - Series Name
1n5 - Capacitance Value = 1,5 nF
4 kV - Rated Voltage

For Model Size > 9 mm

KEKO
KV 3n3
4 kV
KEKO - Tradename
KV - Series Name
3n3 - Capacitance Value = 3,3 nF
4 kV - Rated Voltage

6 kV
For Model Size < 9 mm
KV n47
5 kV

KV - Series Name
n47 - Capacitance Value = 470 pF
5 kV - Rated Voltage

For Model Size = 9 mm

KEKO
KV 1n5
6 kV
KEKO - Tradename
KV - Series Name
1n5 - Capacitance Value = 1,5 nF
6 kV - Rated Voltage

For Model Size > 9 mm

KEKO
KV 4n7
6 kV
KEKO - Tradename
KV - Series Name
4n7 - Capacitance Value = 4,7 nF
6 kV - Rated Voltage

Tape & Reel Specification

Conforms to IEC Publication 286-2 Ed.3 : 2008-03

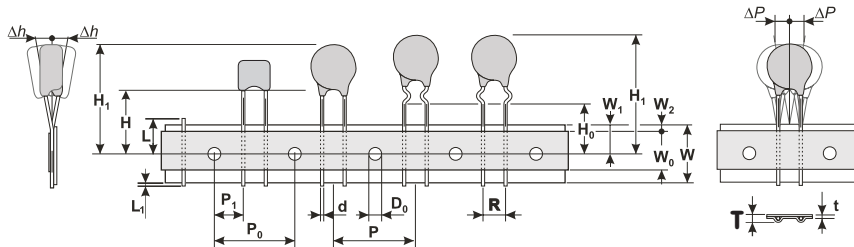

R = 5 mm

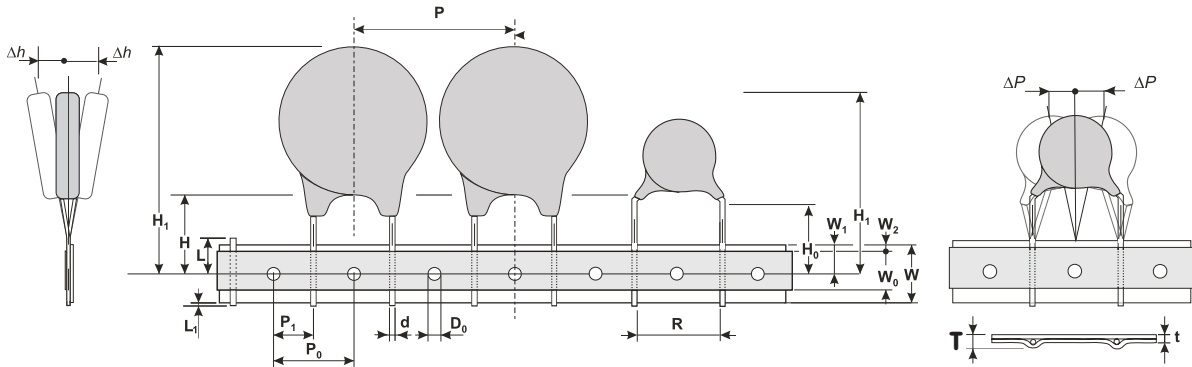

R = 7.5 mm, 10 mm

Symbol	Parameter	Model Size		
		R = 5 mm	R = 7.5 mm	R = 10 mm
Dimension (mm)				
W	Carrier tape width	18 +1.0/-0.5	18 +1.0/-0.5	18 +1.0/-0.5
W₀	Hold down tape width	5 min	5 min	5 min
W₁	Sprocket hole position	9 +0.75/-0.5	9 +0.75/-0.5	9 +0.75/-0.5
W₂	Distance between the upper edges of the carrier tape and hold-down tape	3 max	3 max	3 max
T	Total tape thickness	1,5 Max	1,7 max	1,9 max
t	Tape thickness	0,9 Max	0,9 Max	0,9 Max
P	Pitch of component	12.7 ± 1.0	25.4 ± 1.0*	25.4 ± 1.0
P₀	Feed hole pitch	12.7 ± 0.3	12.7 ± 0.3	12.7 ± 0.3
P₁	Feed hole center to pitch	3.85 ± 0.7	8.95 ± 0.7	7.7 ± 0.7
R	Lead Spacing	5 +0.5/-0.2	7.5 +0.5/-0.2	10 +0.5/-0.2
ΔP	Component alignment	± 1.3 max	± 1.3 max	± 1.3 max
Δh	Component alignment	± 2 max	± 2 max	± 2 max
d	Wire diameter	0.6 max	0.8 max	1 max
D₀	Feed hole diameter	4 ± 0.2	4 ± 0.2	4 ± 0.2
H	Height from tape center to comp. base	18 +2.0/-0.0	18 +2.0/-0.0	18 +2.0/-0.0
H₀	Seating plane height	16 ± 0.5	16 ± 0.5	16 ± 0.5
H₁	Component height	32.2 max	46.5 max	46.5 max
L	Protrusion - cut out	11 max	11 max	11 max
L₁	Protrusion - cut off	0.5 max	0.5 max	0.5 max

* - P = 12,7 mm ± 1.0 for KM 3,3 nF to 6,8 nF

* - P = 12,7 mm ± 1.0 for KZL 330 pF to 2,2 nF

Packaging

Reel

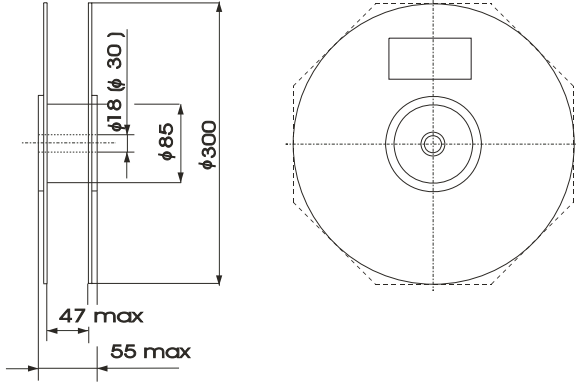

Ammo pack

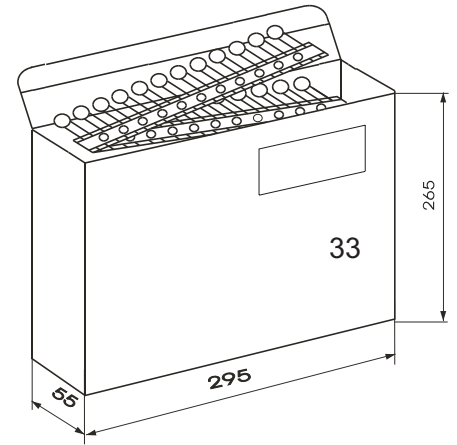

Package units

C (pF)	Bulk			Reel			Ammo		
	KM-Y2	KZL-X1/Y2	KZH-X1/Y1	KM-Y2	KZL-X1/Y2	KZH-X1/Y1	KM-Y2	KZL-X1/Y2	KZH-X1/Y1
330		1500	1500		1300	600		1600	1000
470		1500	1500		1300	600		1600	1000
680		1500	1500		1300	600		1600	1000
1000	1500	1500	1000	1500	1200	600	1800	1400	1000
1500	1000	1000	1000	1500	1200	600	1800	1400	1000
1800	1000	1000	1000	1500	1200	600	1800	1400	1000
2200	1000	1000	1000	1500	1200	600	1800	1400	1000
2500	1000	1000	1000	1500	1200	600	1800	1400	1000
3300	600	500	1000	1200	600	500	1500	700	1000
3900	600	500	500	1200	600	500	1500	700	600
4700	600	500	500	1200	600	500	1500	700	600
5000	600			1200			1500		
6800	600			600			700		
8200	300			600			700		
10000	300			600			700		

C (pF)	Bulk			Reel			Ammo		
	KV - 2kV	KV - 4kV	KV - 6kV	KV - 2kV	KV - 4kV	KV - 6kV	KV - 2kV	KV - 4kV	KV - 6kV
330		1500	1500		1300	600		1600	1000
470		1500	1500		1300	600		1600	1000
680		1500	1500		1300	600		1600	1000
1000	1500	1500	1000	1500	1200	600	1800	1400	1000
1500	1000	1000	1000	1500	1200	600	1800	1400	1000
1800	1000	1000	1000	1500	1200	600	1800	1400	1000
2200	1000	1000	1000	1500	1200	600	1800	1400	1000
2500	1000	1000	1000	1500	1200	600	1800	1400	1000
3300	600	500	1000	1200	600	500	1500	700	1000
3900	600	500	500	1200	600	500	1500	700	600
4700	600	500	500	1200	600	500	1500	700	600
5000	600			1200			1500		
6800	600			600			700		
8200	300			600			700		
10000	300			600			700		

Assembly Recommendations for TH Components



Very often before soldering of through-hole component its leads are being bent. It is important not to damage the component during lead bending. Typical damage produced during bending are cracks in epoxy pants, which can lead to increased humidity sensitivity of component and consequentially to its shorter life time.

- In order to avoid epoxy pants damage it is necessary to :
- fix the most sensitive point (epoxy pants) of component body
 - bend wire at least 2 mm below the end of epoxy pants

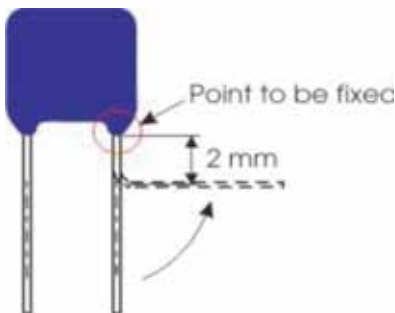

Another potential damage of the component which can lead to component failure or shorter life time is thermal shock during manual soldering by soldering iron. This happens in case soldering iron is placed too close to one point of component body and most often it happens if solder joint is too close to varistor body.

◦ **Resistance to Soldering Heat**

In case of automatic wave soldering it is important to provide sufficient resistance to soldering heat. In order to prevent any potential problems KEKO VARICON decided to introduce its own internal standard for testing of resistance to soldering heat of through-hole components: 300 °C, 10 s.

◦ **Pb-free Wave Soldering Profile Recommendations**

Recommended soldering profiles for all above components are in accordance with JEDEC standard curves (J-STD-020D) and therefore compatible with new Pb-free process.

◦ **Lead-free Wave Soldering Profile**

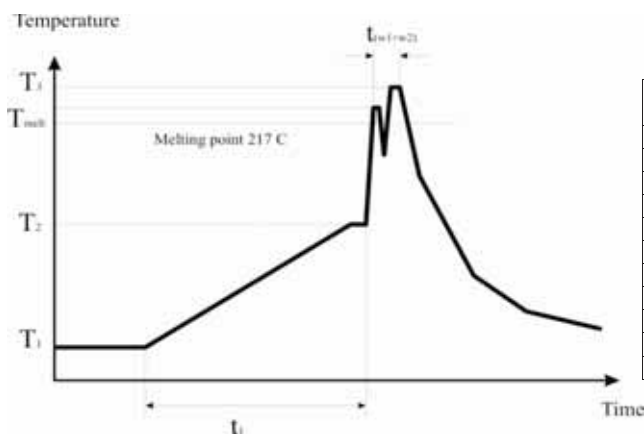

Pb-free wave soldering profile requirements for soldering heat resistance of components		
Parameters	Symbol	Specification
Preheating temperature gradient		4 °C/s max.
Preheating time	t_1	2 to 5 min
Min. preheating temperature	T_1	130 °C
Max. preheating temperature	T_2	180 °C
Melting temperature /point	T_{melt}	217 °C
Time in wave soldering phase ($w_1 + w_2$)	$t_{w_1+w_2}$	10 s
Max. wave temperature ($w_1 + w_2$)	T_3	265 °C +0/-5 °C
Cooling temperature gradient		6 °C/s max.
Temperature jump from T_2 to $T_{3(w)}$	$T_{3(w)} - T_2$	120 °C max
Time from 25 °C to T_3 (wave temperature)		8 min max.

MULTILAYER CERAMIC CAPACITORS C and CL SERIES

Description

Multilayer ceramic capacitors cover capacitance range from 1pF to 10μF, operating voltages from 16Vdc up to 10kVdc. KEKO VARICON offers THD(leaded) and SMD products.

Such capacitors are suited for by-pass and coupling applications or for frequency discriminating circuits. KEKO VARICON also offers multilayer ceramic chip SAFETY capacitors (class X and Y) and Line-by-pass and Across the Line Capacitors.

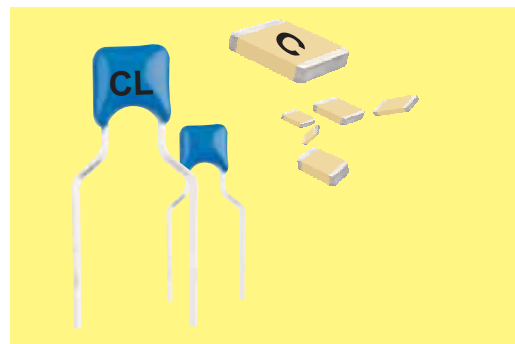

Features

- Capacitance range1 pF to 10μF.
- Rated DC Voltage U_r 16,24,50,100,250,300,500, 1kV to 10kV.
- 19 Model sizes available0603 up to 9080 for SMD components.
- 4 Model sizes available..... 602, 802, 902, 1103 for Leaded components.
- Dielectric Types NPo, X7R / Y5V / Z5U.
 - Npo(CG) - dielectric constant around 90 (very stable characteristics-T,f,U, low capacitance).*
 - X7R(2R1) - dielectric constant around 3000 (higher capacitance in the same case size as Npo).*
 - Y5V,Z5U(2F4) - dielectric constant around 15000 (very high capacitance in small case sizes).*
- Maximum operating temperature - +85 °C.
- Safety capacitors class X and Y, Line-by-pass and Across the Line Capacitors
- Available with straight and crimped leads.
- Lead free components. ^{us}
- UL, CSA approval.

	DIELECTRIC		
	NPo (CG)	X7R (2R1)	Y5V (2F4)
Capacitance range	1 pF to 10μF		
Capacitance tolerance *	C, D, G, J, K, M	K, M, S, Z	M, S, Z
Dissipation Factor tg δ	15*10 ⁻⁴ for C≥50pF or 1.5*(150/C+7)*10 ⁻⁴	350*10 ⁻⁴	350*10 ⁻⁴
Measuring Frequency (for C and tg δ)	1 MHz for C≤1000pF 1 kHz for C>1000pF	1 MHz for C≤100pF 1 kHz for C>100pF	1 kHz
Measuring Voltage (C, tg δ)	1 Vrms	0.3 Vrms	0.3 Vrms
Rated Voltage	16V - 10kV		
Test Voltage (16V -10kV)**	16V-100V = 2,5*Ur 200V-500V = 1,5*Ur+100V > 500V = 1,2*Ur		
Insulating Resistance Ri	Ri≥10000MΩ (for Cr≤10nF) Ri≥100/Cr [Ω] (for Cr>10nF)	Ri≥4000MΩ (for Cr≤25nF) Ri≥100/Cr [Ω] (for Cr>25nF)	
Measuring Voltage for Ri	16 - 1kV= Ur		
Temperature Range	-55°C to +125°C	-55°C to +125°C	-25°C to +85°C
Temperature Characteristics	0±30ppm/°C	±15%	±30% / -80%
Climatic Categoroz	55 / 125 / 56	55 / 125 / 56	25 / 85 / 21
Temperature Range	23°C		
Voltage Dependence	No	Yes	Yes
Aging (per hour decade)	0	<2%	<6%
Termination (chip)	AgPd or Ni barrier		
Packaging	Bulk or Taped		
Standard	IEC 60384-21,22 for SMD; IEC 60384-8,9 for leaded THD IEC 60286-3 for taped SMD; IEC 60286-3 for taped leaded THD		

SMD Sizes - C series

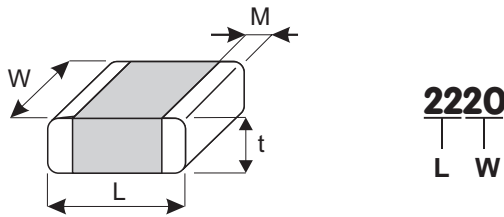

SMD Table

Size	L (mm)	W (mm)	M (mm)	tmax (mm)
0603	1,6 ± 0,20	0,8 ± 0,10	0,5 ± 0,25	1,0
0805	2,0 ± 0,25	1,25 ± 0,20	0,5 ± 0,25	1,2
1206	3,2 ± 0,30	1,6 ± 0,20	0,5 ± 0,25	1,5
1210	3,2 ± 0,30	2,5 ± 0,25	0,5 ± 0,25	2,5
1515	3,8 ± 0,40	3,8 ± 0,40	0,5 ± 0,25	3,5
1808	4,7 ± 0,40	2,0 ± 0,30	0,5 ± 0,25	2,0
1812	4,7 ± 0,40	3,2 ± 0,30	0,5 ± 0,25	3,0
1825	4,7 ± 0,40	6,3 ± 0,40	0,5 ± 0,25	3,0
2220	5,7 ± 0,50	5,0 ± 0,40	0,5 ± 0,25	3,0
2225	5,7 ± 0,50	6,3 ± 0,40	0,5 ± 0,25	3,0
2520	6,3 ± 0,50	5,0 ± 0,50	0,5 ± 0,25	4,5
3225	8,0 ± 0,50	6,3 ± 0,40	0,5 ± 0,25	4,5
3640	9,1 ± 0,90	10,2 ± 1,0	0,5 ± 0,25	5,1
4012	10,2 ± 1,0	3,2 ± 0,30	0,5 ± 0,25	5,1
4032	10,2 ± 1,0	8,1 ± 0,80	0,5 ± 0,25	5,1
5040	12,7 ± 1,3	10,2 ± 1,0	0,5 ± 0,25	5,1
5550	14,0 ± 1,4	12,7 ± 1,3	0,5 ± 0,25	6,4
6660	16,7 ± 1,7	15,2 ± 1,6	0,5 ± 0,25	6,4
7565	19,1 ± 1,9	16,5 ± 1,6	0,5 ± 0,25	7,0
9080	22,9 ± 2,3	20,3 ± 2,0	0,5 ± 0,25	8,0

THD Sizes - CL series

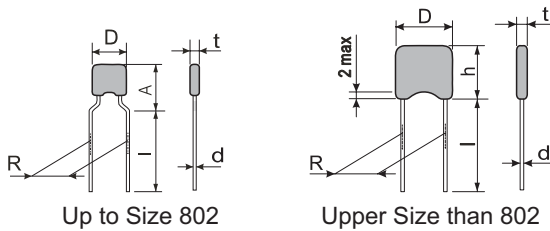

THD Table

Size	up to 381 or 382			up to 481 or 482			602			up to 802 or 804			up to 962 or 964		144		186		246	
D max (mm)	3.8			4.8			6			8			9.6		14		18		24	
R (mm)	2.5 or 5			2.5 or 5			5			5 or 10			5 or 10		10		15		15	
t max (mm)	3			4.5			4.5			4.5			5.5		5.5		6.5		6.5	
d (mm)	0.5			0.6			0.6			0.6			0.6		0.8		0.8		0.8	
Dielectric R. Voltage	Npo	X7R	Y5V	Npo	X7R	Y5V	Npo	X7R	Y5V	Npo	X7R	Y5V	Npo	X7R	Npo	X7R	Npo	X7R	Npo	X7R
	50V	222	104	224	183	394	105	653	125	685	653	125	685	823	225	154	225			
100V	222	823	154	822	334	684	473	105	475	473	105	475	683	185	124	185				
250V	122	153	563	472	104	274	223	684	105	223	684	105	473	474	823	474				
300V	331	682	273	332	473	104	153	334	684	153	334	684	223	224	563	224				
500V	271	472	153	182	333	473	822	154	124	822	154	124	153	104	333	104				
1kV	181	182		122	123		682	683		682	683		822	823	183	823	393	474	104	105
2kV				561	222		332	273		332	273		562	123	123	273	273	823	683	334
3kV							152	682		152	682		222	562	682	562	153	563	393	184
4kV							821	182		821	182		152	332	472	332	103	273	223	104
5kV							331	102		331	102		561	222	222	222	392	153	123	473
6kV													680		122	222	272	123	682	333
7kV															821	222	182	822	562	223
8kV																	562	562	472	153
9kV																	102	472	332	123
10kV																	561	332	272	103

Marking of THD - CL Series



105 - Capacitance Code - see tables Device Ratings and characteristics (Code).
 $C_n = 10^{-1} \times 10^5 = 10^{-6} F = 1 \mu F$
100V - Rated Voltage $V_n = 100V$. Note: Rated Voltage is marked on size 80x and above. On smaller sizes is marked upon request only.

Ordering Information

C series

C 10nF K X7R 500 Y2 1206 N R yy

- C** - Series Name : C
- 10 nF** - Capacitance value
- K** - Capacitance Tolerance : K = ± 10 %, M = ± 20 %
- X7R** - Dielectric : NPo(CG),X7R(2R1),Y5V(2F4)
- 500** - Rated AC Voltage : 500=50*10⁰=50V, 501=50V
- Y2** - Sub-Class if appropriate : Y1,Y2,Y3,X1,X2,X3 by IEC60384-14
- 1206** - Size : see table above- SMD sizes
- N** - Barrier type end terminations suitable for Pb-free reflow soldering
 - (no letter) AgPd end terminations suitable for Pb reflow soldering
- R** - Packaging : R = Reel, A = Ammo Pack, B = Bulk
- yy** - Special requirements

CL series

CL 10nF K X7R 500 Y2 382 R L1 yy

- CL** - Series Name : CL
- 10 nF** - Capacitance value
- K** - Capacitance Tolerance : K = ± 10 %, M = ± 20 %
- X7R** - Dielectric : NPo(CG),X7R(2R1),Y5V(2F4)
- 500** - Rated AC Voltage : 500=50*10⁰=50V, 501=50V
- Y2** - Sub-Class if appropriate : Y1,Y2,Y3,X1,X2,X3
- 382** - Size : see table above- THD sizes
- R** - Packaging : R = Reel, A = Ammo Pack, B = Bulk
- L1** - Lead Style : 1 = straight, 5 = crimped
- yy** - Special requirements

Device Ratings and Characteristics

NPo(CG) // 50V and 100V

NPo (CG)

Size	0603		0805		1206		1210		1808		1812		2220		2225	
	Rated Voltage															
Cn Code	50V	100V	50V	100V	50V	100V	50V	100V	50V	100V	50V	100V	50V	100V	50V	100V
1 - 8,2pF							100		100		100					
10 100																
12 120																
15 150																
18 180																
22 220																
27 270													270		270	
33 330																
39 390																
47 470																
56 560																
68 680																
82 820																
100 101																
120 121																
150 151																
180 181																
220 221																
270 271																
330 331																
390 391																
470 471																
560 561																
680 681																
820 821		681														
1nF 102																
1.2 122																
1.5 152																
1.8 182																
2.2 222																
2.7 272																
3.3 332				272												
3.9 392	332															
4.7 472																
5.6 562																
6.8 682																
8.2 822						682										
10 103								822		822						
12 123			103													
15 153																
18 183																
22 223																
27 273												223				
33 333																
39 393					333		333		333		333					
47 473																
56 563														473		473
68 683													563		563	
82 823																
100 104																
120 124																
150 154																
180 184																
220 224																
270 274																
330 334																
390 394																

Device Ratings and Characteristics

X7R(2R1) // 50V and 100V

X7R (2R1)

Size																
	0603		0805		1206		1210		1808		1812		2220		2225	
Cn Code	Rated Voltage															
	50V	100V	50V	100V	50V	100V	50V	100V	50V	100V	50V	100V	50V	100V	50V	100V
100 pF	101															
120	121															
150	151															
180	181															
220	221															
270	271					331										
330	331															
390	391						471	471								
470	471															
560	561															
680	681															
820	821										102					
1 nF	102															
1.2	122															
1.5	152															
1.8	182												222		222	
2.2	222															
2.7	272															
3.3	332															
3.9	392															
4.7	472															
5.6	562															
6.8	682															
8.2	822															
10	103															
12	123															
15	153															
18	183															
22	223															
27	273		223													
33	333															
39	393															
47	473															
56	563															
68	683															
82	823															
100	104															
120	124	104														
150	154			104												
180	184															
220	224															
270	274															
330	334															
390	394			334												
470	474															
560	564					474		474		474						
680	684															
820	824										684					
1 μF	105															
1.2	125					105		105		105				105		
1.5	155															
1.8	185															
2.2	225												155		155	
2.7	275															
3.3	335															
3.9	395															
4.7	475															
5.6	565															
6.8	685															

Device Ratings and Characteristics

Y5V, Z5U (2F4) // 50V and 100V







Y5V (Z5U)

Size																	
	0603		0805		1206		1210		1808		1812		2220		2225		
		Rated Voltage															
Cn	Code	50V	100V	50V	100V	50V	100V	50V	100V	50V	100V	50V	100V	50V	100V	50V	100V
2.2nF	222																
2.7	272																
3.3	332																
3.9	392																
4.7	472					472											
5.6	562																
6.8	682																
8.2	822																
10	103							103		103							
12	123																
15	153																
18	183																
22	223																
27	273																
33	333																
39	393		333														
47	473												222				
56	563																
68	683																
82	823																
100	104												104		104		
120	124																
150	154																
180	184																
220	224				184												
270	274	224															
330	334																
390	394																
470	474																
560	564																
680	684																
820	824					684											
1 uF	105																
1.2	125		105														
1.5	155							125		125							
1.8	185																
2.2	225																
2.7	275					225		225		225			225				
3.3	335																
3.9	395												275				
4.7	475																
5.6	565																
6.8	685																
8.2	825																
10	106																
12	126																
15	156												106		825		
18	186															106	825
22	226																
27	276																
33	336																
39	396																
47	476																
56	566																
68	686																
82	826																

Device Ratings and Characteristics

NPo(CG) // 250V, 300V and 500V







NPo (CG)

Size																					
	0805			1206			1210			1808			1812			2220			2225		
Cn Code	Rated Voltage																				
	250V	300V	500V	250V	300V	500V	250V	300V	500V	250V	300V	500V	250V	300V	500V	250V	300V	500V	250V	300V	500V
1 - 8,2pF								100			100			100							
10 100																					
12 120																					
15 150																					
18 180																					
22 220																					
27 270																	270			270	
33 330																					
39 390																					
47 470																					
56 560																					
68 680																					
82 820																					
100 101																					
120 121																					
150 151																					
180 181																					
220 221																					
270 271																					
330 331																					
390 391																					
470 471																					
560 561			471																		
680 681																					
820 821		681																			
1nF 102																					
1.2 122						102															
1.5 152	122																				
1.8 182																					
2.2 222					182																
2.7 272					272				222												
3.3 332																					
3.9 392												272									
4.7 472															392						
5.6 562																					
6.8 682									562			472									
8.2 822												682			822			682			
10 103																					
12 123																					
15 153																					
18 183																					
22 223																					
27 273																					
33 333																					
39 393																					
47 473																					
56 563																					
68 683																					
82 823																					
100 104																					
120 124																					
150 154																					
180 184																					
220 224																					
270 274																					
330 334																					
390 394																					

Device Ratings and Characteristics

X7R (2R1) // 250V, 300V and 500V







X7R (2R1)

Size																						
	0805			1206			1210			1808			1812			2220			2225			
Cn Code	Rated Voltage																					
	250V	300V	500V	250V	300V	500V	250V	300V	500V	250V	300V	500V	250V	300V	500V	250V	300V	500V	250V	300V	500V	
100 pF 101																						
120 121																						
150 151																						
180 181																						
220 221								221		221			221									
270 271																						
330 331																						
390 391																						
470 471																						
560 561																						
680 681																						
820 820																						
1nF 102																	102			102		
1.2 122																						
1.5 152																						
1.8 182																						
2.2 222																						
2.7 272																						
3.3 332																						
3.9 392																						
4.7 472																						
5.6 562																						
6.8 682			562																			
8.2 822																						
10 103																						
12 123		103																				
15 153																						
18 183						153																
22 223	183																					
27 273				223																		
33 333																						
39 393																						
47 473																						
56 563																						
68 683									563					563								
82 823													683									
100 104																						
120 124																						
150 154																						
180 184																						
220 224																						
270 274								184														
330 334																						
390 394																						
470 474																						
560 564																						
680 684																						
820 824																						
1.0 uF 105																						
1.2 125																						
1.5 155																						
1.8 185																						
2.2 225																						
2.7 275																						
3.3 335																						
3.9 395																						
4.7 475																						
5.6 565																						
6.8 685																						

Device Ratings and Characteristics

Y5V, Z5U (2F4) // 250V, 300V and 500V

Y5V (Z5U)

Size																					
	0805			1206			1210			1808			1812			2220			2225		
Rated Voltage																					
Cn	Code	250V	300V	500V	250V	300V	500V	250V	300V	500V	250V	300V	500V	250V	300V	500V	250V	300V	500V		
2.2 nF	222																				
2.7	272																				
3.3	332							332			332										
3.9	393																				
4.7	472																				
5.6	562																				
6.8	682																				
8.2	822																				
10	103														103						
12	123																				
15	153																				
18	183			153																	
22	223																				
27	273																				
33	333		273																		
39	393																				
47	473																				
56	563					473			473			473									
68	683	563				563															
82	823																				
100	104																				
120	124							104			104				104						
150	154				124																
180	184																				
220	224																				
270	274																				
330	334							274			274				274						
390	394																				
470	474																				
560	564																				
680	684													564							
820	824																				
1.0 uF	105																				
1.2	125																				
1.5	155																				
1.8	185																				
2.2	225																				
2.7	275																				
3.3	335																				
3.9	395																				
4.7	475																				
5.6	565																				
6.8	685																				
8.2	825																				
10	106																				
12	126																				
15	156																				
18	186																				
22	226																				
27	276																				
33	336																				
39	396																				
47	476																				
56	566																				
68	686																				
82	826																				

Device Ratings and Characteristics

NPo(CG) // 1kV - 10kV

NPo (CG)

Size	0805	1206	1210	1515	1808	1812	1825	2220	2225	2520	3640	4012	4032	5040	5550	6660	7565	9080
Cn Code																		
1 - 8,2pF																		
10 100																		
12 120																		
15 150																		
18 180																		
22 220																		
27 270																		
33 330																		
39 390																		
47 470																		
56 560																		
68 680										6kV 820								
82 820																		
100 101																		
120 121					4kV													
150 151																		
180 181					181													
220 221	1kV	2kV			3kV	4kV						7kV						
270 271		271			331	331						271						
330 331	331				331	331	5kV	5kV				6kV 391						
390 391												5kV 561	7kV 471					
470 471		1kV	2kV	3kV	2kV	561			561	561		4kV 821	6kV 821	10kV				
560 561				561										102				
680 681		821			821									9kV 152	10kV			
820 821						2kV	4kV	4kV	4kV	4kV	7kV	3kV 122	5kV 152	8kV 152	10kV			
1nF 102														7kV 272	8kV 272	10kV 272		
1.2 122							122	122	122	152	152	152		9kV 152	10kV			
1.5 152			1kV	2kV	1kV		182	3kV 182	3kV 182	3kV 222	3kV 222		4kV 272	6kV 272	8kV 272	10kV 272		
1.8 182			182											7kV 392	8kV 392	10kV 392		
2.2 222				222	222	222							5kV	4kV 272	6kV 272	8kV 272	10kV 272	
2.7 272														3kV 392	5kV 392	6kV 392	8kV 392	10kV 392
3.3 332							392	392										
3.9 392																		
4.7 472																		
5.6 562							1kV	1kV		2kV 682	4kV	2kV 682	2kV					
6.8 682																		
8.2 822							822	822	2kV 103	1kV 103	822	3kV 123	1kV 123	822	4kV 103			
10 103									1kV 123				1kV 153	3kV 153	4kV 153	5kV 123	6kV 153	7kV 153
12 123																		
15 153																		
18 183																		
22 223														2kV 223	3kV 223	4kV 223		
27 273														1kV 333	2kV 393	3kV 393	4kV 393	4kV
33 333																		
39 393																		
47 473																		
56 563															1kV 563	2kV	3kV	4kV
68 683																683	2kV	3kV
82 823																		
100 104																1kV 104	223	2kV
120 124																	1kV 223	104
150 154																		154
180 184																		
220 224																		
270 274																		
330 334																		
390 394																		

Device Ratings and Characteristics

X7R (2R1) // 1kV - 10kV

X7R (2R1)

Size	0805	1206	1210	1515	1808	1812	1825	2220	2225	2520	3640	4012	4032	5040	5550	6660	7565	9080
Cn Code																		
100 pF	101																	
120	121																	
150	151																	
180	181																	
220	221																	
270	271																	
330	331																	
390	391																	
470	471					4kV												
560	561					561												
680	681		2kV		3kV													
820	821		821		821			5kV					6kV					
1 nF	102			3kV				102					102					
1.2	122			122				152					152					
1.5	152					3kV	4kV	4kV					152					
1.8	182	1kV				182	182	182					222	7kV				
2.2	222	222				272			4kV	222			272	4kV	10kV			
2.7	272		2kV			272			272				272	6kV	332			
3.3	332				2kV					4kV				332	332			
3.9	392				392					392					9kV			
4.7	472														472			
5.6	562		1kV				2kV	3kV	3kV					562	8kV			
6.8	682		682			682	682	682							7kV	10kV		
8.2	822							822	3kV	3kV	7kV			822	822	10kV		
10	103			1kV						2kV	6kV		4kV	6kV	9kV	103		
12	123			123						153	123		123	123	8kV	9kV		
15	153					1kV					183	2kV		183	7kV	8kV		
18	183					183					183			183	6kV	7kV	10kV	
22	223						2kV	2kV			273		223	223	223	223	223	10kV
27	273						273	273			273		2kV	273	273	6kV	9kV	273
33	333								2kV		3kV		333	3kV	5kV	333	8kV	9kV
39	393								393		393			393	393	5kV	7kV	8kV
47	473														473	473	6kV	7kV
56	563						1kV								563		563	6kV
68	683						638	1kV									5kV	683
82	823							823		1kV	2kV			2kV	3kV	4kV	823	5kV
100	104								1kV	104	104	1kV		104	104	104		104
120	124								124									124
150	154																	154
180	184																	184
220	224																	224
270	274																	274
330	334																	334
390	394										1kV							394
470	474										474							474
560	564																	564
680	684																	684
820	824													1kV				824
1 uF	105															1kV		105
1.2	125															125		125
1.5	155																	155
1.8	185																	185
2.2	225																	225
2.7	275																	275

SOLDERING RECOMMENDATIONS

Popular soldering techniques used for surface mount components are Wave and Infrared Reflow processes. Both processes can be performed with Pb-containing or Pb-free solders. The termination options available for these soldering techniques are AgPd and Barrier Type End Terminations.

End termination	Designation	Recommended and Suitable for	Component RoHS Compliant
Ag/Pd	Series _(ZV,AV,DV,C,...)R1	Pb-containing soldering	Yes
Barrier Type End Termination	Series _(ZV,AV,DV,C,...)N R1	Pb-containing and Pb-free soldering	Yes

Wave Soldering - this process is generally associated with discrete components mounted on the underside of printed circuit boards, or for large top-side components with bottom-side mounting tabs to be attached, such as the frames of transformers, relays, connectors, etc. SMD varistors to be wave soldered are first glued to the circuit board, usually by an epoxy adhesive. When the PCB has been fully populated and an appropriate time is allowed for adhesive curing, the completed assembly is then placed on a conveyor and run through a single or double wave process.

Infrared Reflow Soldering - these reflow processes are typically associated with top-side component placement. This technique utilizes a mixture of adhesive and solder compounds (and sometimes fluxes) that are blended into a paste. The paste is then screened onto PCB soldering pads specifically designed to accept a particular sized SMD component. Recommended solder paste wet layer thickness is 100 to 300 μm. Once the circuit board is fully populated with SMD components, it is placed in a reflow environment, where the paste is heated to slightly above its eutectic temperature. When the solder paste reflows, the SMD components are attached to the solder pads.

Solder Fluxes - solder fluxes are generally applied to populated circuit boards to prevent oxides from forming during the heating process and to facilitate the flowing of the solder. Solder fluxes can be either a part of the solder paste compound or can be separate materials, usually fluids. Recommended fluxes are:

- Non-activated (R) fluxes, whenever possible
- Mildly activated (RMA) fluxes of class L3CN
- Class ORLO

Activated (RA), water soluble or strong acidic fluxes with chlorine content > 0.2 wt.% are **NOT RECOMMENDED**. Use of such fluxes could create high leakage current paths along the body of the varistor components.

When a flux is applied prior to wave soldering, it is important to completely dry any residual flux solvents prior to the soldering process.

Solders - recommended solders are Pb-free (Sn96 / Cu0,4-0,8/ Ag3-4) or Pb-containing (62Sn / 36Pb / 2Ag) ones.

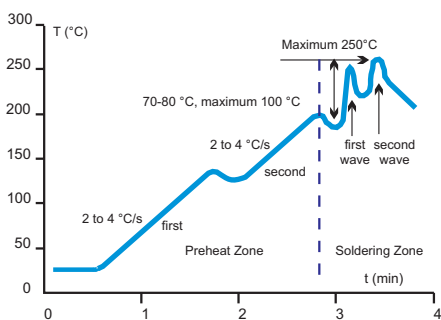

Fig. 1. Wave Soldering Temperature Profile for Pb-free and Pb-containing Soldering

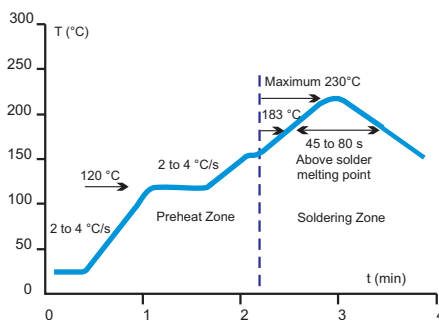

Fig. 2. Infrared Reflow Temperature Profile for Pb-containing Soldering

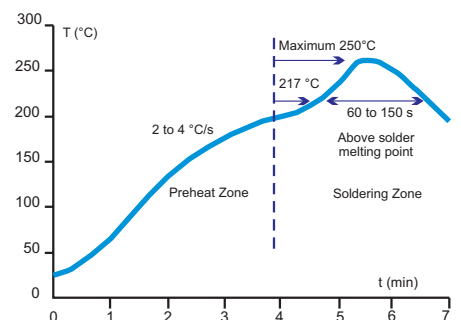

Fig. 3. Reflow Temperature Profile for Pb-free Soldering

Thermal Shock - to avoid the possibility of generating stresses in the varistor chip due to thermal shock, a preheat stage to within 100 °C of the peak soldering process temperature is recommended. Additionally, SMD varistors should not be subjected to a temperature gradient greater than 4 °C/sec, with an ideal gradient being 2 °C/sec. Peak temperatures should be controlled. Wave and Reflow soldering conditions for SMD varistors with Pb-containing solders are shown in Fig. 1 and 2 respectively, while Wave and Reflow soldering conditions for SMD varistors with Pb-free solders are shown in Fig. 1 and 3.

Whenever several different types of SMD components are being soldered, each having a specific soldering profile, the soldering profile with the least heat and the minimum amount of heating time is recommended. Once soldering has been completed, it is necessary to minimize the possibility of thermal shock by allowing a hot PCB to cool to less than 50 °C before cleaning.

Inspection Criteria - the inspection criteria to determine acceptable solder joints, when Wave or Infrared Reflow processes are used, will depend on several key variables, principally termination materials and process profiles.

Pb-containing Wave and IR Reflow Soldering - typical “before” and “after” soldering results for Silver/Palladium (AgPd) and Barrier Type End Terminations are given in Fig. 4. Both barrier type and silver/palladium terminated varistors form a reliable electrical contact and metallurgical bond between the end terminations and the solder pads. The bond between these two metallic surfaces is exceptionally strong and has been tested by both vertical pull and lateral (horizontal) push tests. The results, in both cases, exceed established industry standards for adhesion.

The solder joint **appearance** of a barrier type terminated versus a silver/palladium terminated varistor will be slightly different. Solder forms a metallurgical junction with the thin tin-alloy (over the barrier layer), and due to its small volume “climbs” the outer surface of the termination, forming a classical meniscus. Due the surface tension characteristics of silver/palladium terminations, the meniscus will be slightly lower. This optical appearance difference should be taken into consideration when programming visual inspection of the PCB after soldering.

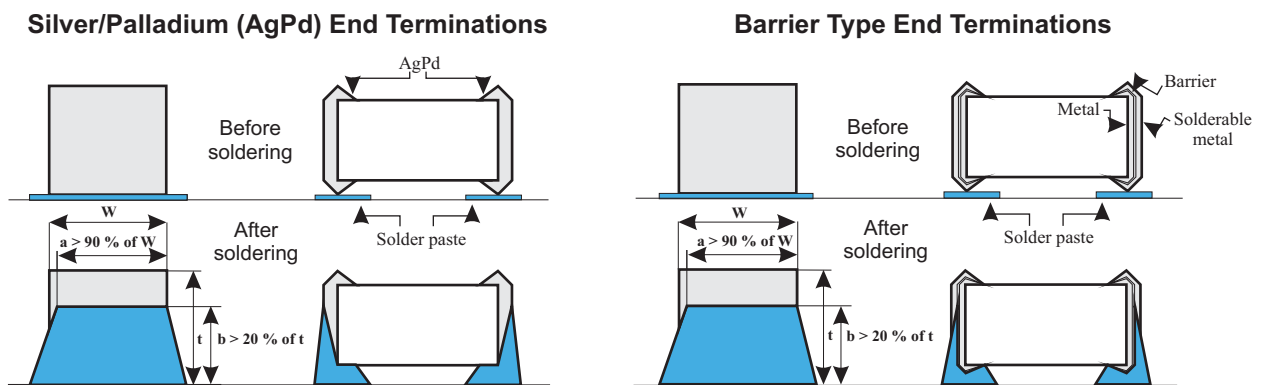

Fig. 4. Soldering Criterion in case of Wave and IR Reflow Pb-containing Soldering

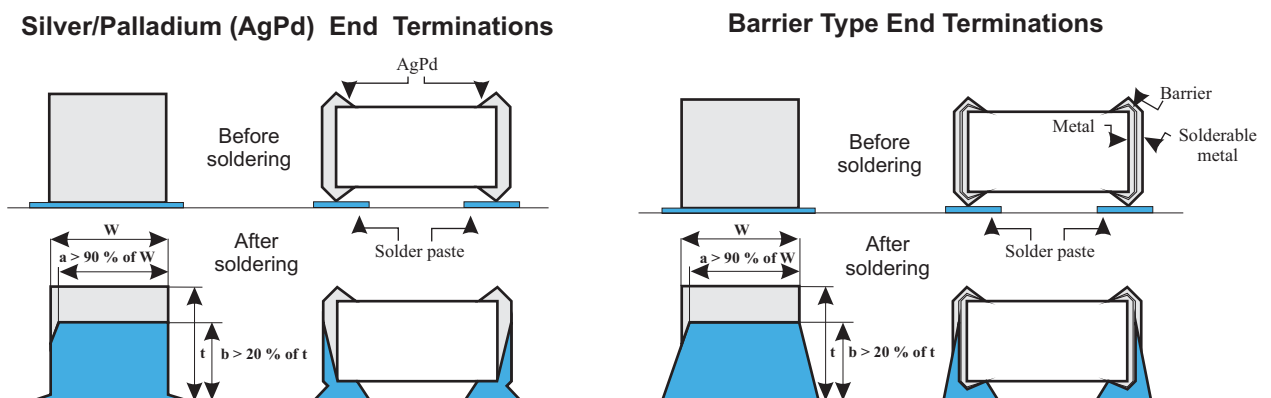

Fig. 5. Soldering Criterion in case of Wave and IR Reflow Pb-free Soldering

Pb-free Wave and IR Reflow Soldering - typical “before” and “after” soldering results for Silver/Palladium (AgPd) and Barrier Type End Terminations are given in Fig. 5. Barrier type varistor terminations provide standard meniscus and are recommended for Pb-free soldering.

A phenomenon known as “mirror” or “negative” meniscus results will appear in case of Silver/Palladium terminated varistors. Solder forms a metallurgical junction with the entire volume of the end termination, i.e. it diffuses from pad to end termination across the inner side, forming a “mirror” or “negative” meniscus. The height of the solder penetration can be clearly seen on the end termination and is always higher than 30% of the chip height.

Since barrier type terminations on KEKO-VARICON chips do not require the use of problematic nickel and tin-alloy electroplating processes, these varistors are truly considered **environmentally friendly**.

Solder Tests and Retained Samples - reflow soldering test based on J-STD-020D.1 and soldering test by dipping based on IEC 60068-2 for Pb-free solders are performed on each production lot as shown in the following chart. Test results and accompanying samples are retained for a minimum of two (2) years. Solderability of a specific lot can be checked at any time within this period should a customer require this information.

Test	Resistance to flux	Solderability	Static leaching (simulation of Reflow Soldering)	Dynamic leaching (simulation of Wave Soldering)
Parameter				
Soldering method	dipping	dipping	dipping	dipping with agitation
Flux	L3CN, ORL0	L3CN, ORL0, R	L3CN, ORL0, R	L3CN, ORL0, R
Pb Solder	96,5Sn / 3,5Ag			
Pb Soldering temperature (°C)	235 ± 5	235 ± 5	260 ± 5	235 ± 5
Pb-FREE Solder	Sn96 / Cu0,4-0,8 / 3-4Ag			
Pb-FREE Soldering temperature (°C)	250 ± 5	250 ± 5	280 ± 5	250 ± 5
Soldering time (s)	2	2	10	> 15
Burn-in conditions	Vdcm _{ax} , 48 h	-	-	-
Acceptance criterion	dVn < 5 %, I _{dc} must stay unchanged	> 95 % of end termination must be covered by solder	> 95 % of end termination must be intact and covered by solder	> 95 % of end termination must be intact and covered by solder

Rework Criteria Soldering Iron - unless absolutely necessary, the use of soldering irons is NOT recommended for reworking varistor chips. If no other means of rework is available, the following criteria must be strictly followed:

- Do not allow the tip of the iron to directly contact the top of the chip
- Do not exceed the following soldering iron specifications:
 - Output Power: 30 Watts maximum
 - Temperature of Soldering Iron Tip: 280 °C maximum
 - Soldering Time: 10 Seconds maximum

Storage Conditions - SMD varistors should be used within 1 year of purchase to avoid possible soldering problems caused by oxidized terminals. The storage environment should be controlled, with humidity less than 40% and temperature between -25 and 45 °C. Varistor chips should always be stored in their original packaged unit.

Where varistor chips have been in storage for more than 1 year, and where there is evidence of solderability difficulties, KEKO-VARICON can “refresh” the terminations to eliminate these problems.

Soldering Pad Configuration

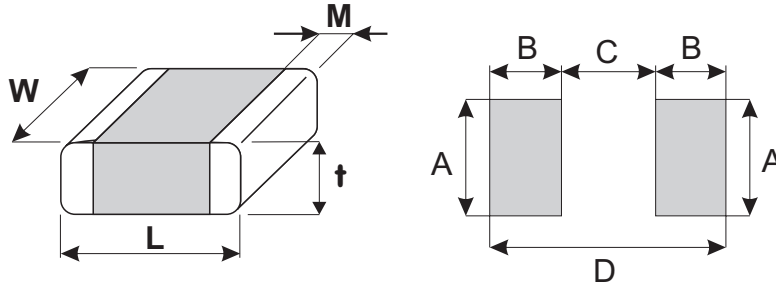

Size	L (mm)	W (mm)	M (mm)	t _{max} (mm)	A (mm)	B (mm)	C (mm)	D (mm)
0603	1,6 ± 0,20	0,8 ± 0,10	0,5 ± 0,25	1,0	1,0	1,0	0,6	2,6
0805	2,0 ± 0,25	1,25 ± 0,20	0,5 ± 0,25	1,2	1,4	1,2	1,0	3,4
1206	3,2 ± 0,30	1,6 ± 0,20	0,5 ± 0,25	1,5	1,8	1,2	2,1	4,5
1210	3,2 ± 0,30	2,5 ± 0,25	0,5 ± 0,25	2,5	2,8	1,2	2,1	4,5
1515	3,8 ± 0,40	3,8 ± 0,40	0,5 ± 0,25	3,5	4,0	1,2	2,3	4,7
1808	4,7 ± 0,40	2,0 ± 0,30	0,5 ± 0,25	2,0	2,4	1,5	3,2	6,2
1812	4,7 ± 0,40	3,2 ± 0,30	0,5 ± 0,25	3,0	3,6	1,5	3,2	6,2
1825	4,7 ± 0,40	6,3 ± 0,40	0,5 ± 0,25	3,0	6,6	1,5	3,2	6,2
2220	5,7 ± 0,50	5,0 ± 0,40	0,5 ± 0,25	3,0	5,5	1,5	4,2	7,2
2225	5,7 ± 0,50	6,3 ± 0,40	0,5 ± 0,25	3,0	6,6	1,5	4,2	7,2
2520	6,3 ± 0,50	5,0 ± 0,50	0,5 ± 0,25	4,5	5,5	1,5	4,6	7,2
3225	8,0 ± 0,50	6,3 ± 0,40	0,5 ± 0,25	4,5	6,8	1,5	6,5	9,5
3640	9,1 ± 0,90	10,2 ± 1,0	0,5 ± 0,25	5,1	10,7	1,5	7,6	10,6
4012	10,2 ± 1,0	3,2 ± 0,30	0,5 ± 0,25	5,1	3,7	1,5	8,7	11,7
4032	10,2 ± 1,0	8,1 ± 0,80	0,5 ± 0,25	5,1	8,6	1,5	8,7	11,7
5040	12,7 ± 1,3	10,2 ± 1,0	0,5 ± 0,25	5,1	10,7	1,5	11,2	14,2
5550	14,0 ± 1,4	12,7 ± 1,3	0,5 ± 0,25	6,4	13,2	1,5	12,5	15,5
6660	16,7 ± 1,7	15,2 ± 1,6	0,5 ± 0,25	6,4	15,7	1,5	15,2	18,2
7565	19,1 ± 1,9	16,5 ± 1,6	0,5 ± 0,25	7,0	17,0	1,5	17,6	20,6
9080	22,9 ± 2,3	20,3 ± 2,0	0,5 ± 0,25	8,0	20,8	1,5	21,4	24,4

Tape and Reel Specification

Conforms to IEC Publication 286 - 3 Ed.4 : 2007-06

Tape

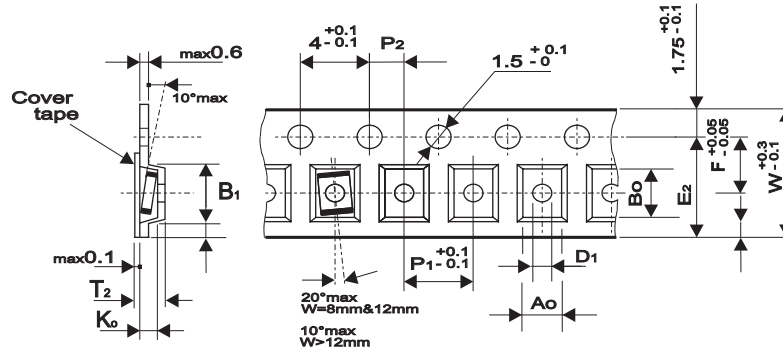

Reel

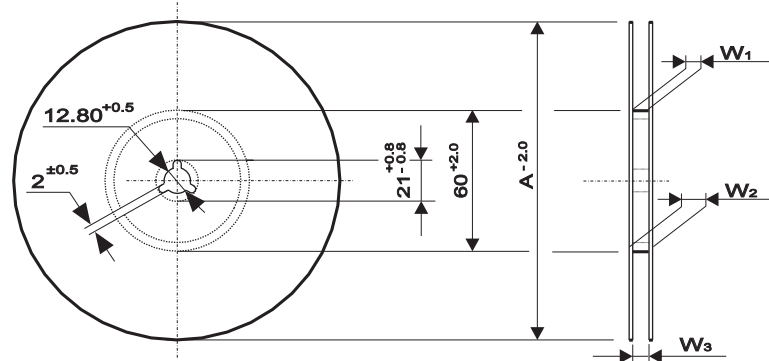

Variable dimensions

Tape Size		8 mm				12 mm		16 mm	
Size	Units	0603	0805	1206	1210	1808/1812/1825	2220/2225	3225	4032
Ao	(mm)	1,2	1,6	1,9	2,9	2,4/3,75/7	5,6/7	7	8,6
Bo	(mm)	1,9	2,4	3,75	3,7	5	6,25	8,7	10,8
Ko max	(mm)	3,5	3,5	3,5	3,5	6,5	6,5	9,5	9,5
B1 max	(mm)	4,35	4,35	4,35	4,35	8,2	8,2	12,1	12,1
D1 min	(mm)	0,3	0,3	0,3	0,3	1,5	1,5	1,5	1,5
Ez min	(mm)	6,25	6,25	6,25	6,25	10,25	10,25	14,25	14,25
P1	(mm)	4	4	4	4	8	8	12	12
F	(mm)	3,5	3,5	3,5	3,5	5,5	5,5	7,5	7,5
W	(mm)	8,0	8,0	8,0	8,0	12,0	12,0	16,0	16,0
T2 max	(mm)	3,5	3,5	3,5	3,5	6,5	6,5	9,5	9,5
W1	(mm)	8,4+1,5	8,4+1,5	8,4+1,5	8,4+1,5	12,4+2	12,4+2	16,4+2	16,4+2
W2 max	(mm)	14,4	14,4	14,4	14,4	18,4	18,4	22,4	22,4
W3	(mm)	7,9...10,9	7,9...10,9	7,9...10,9	7,9...10,9	11,9...15,4	11,9...15,4	15,9...19,4	15,9...19,4
A	(mm)	180/330	180/330	180/330	180/330	180/330	180/330	330	330

Package units

Series	Package	Chip Size									
		0603 / 0805 / 1206 / 1210		1808 / 1812		1825 / 2220 / 2225		3225 / 4032		1515	
		Reel size		Reel size		Reel size		Reel size		Reel size	
C	Reel	4000	15000	1500	6000	1000	4000	/	2500	/	/
	Bulk	12000		3000		3000		3000		3000	

NOTE : Quantity per reel varies with the chip thickness.
Other chip sizes are taped on REQUEST.

Tape & Reel Specification

Conforms to IEC Publication 286-2 Ed.3 : 2008-03

Packaging

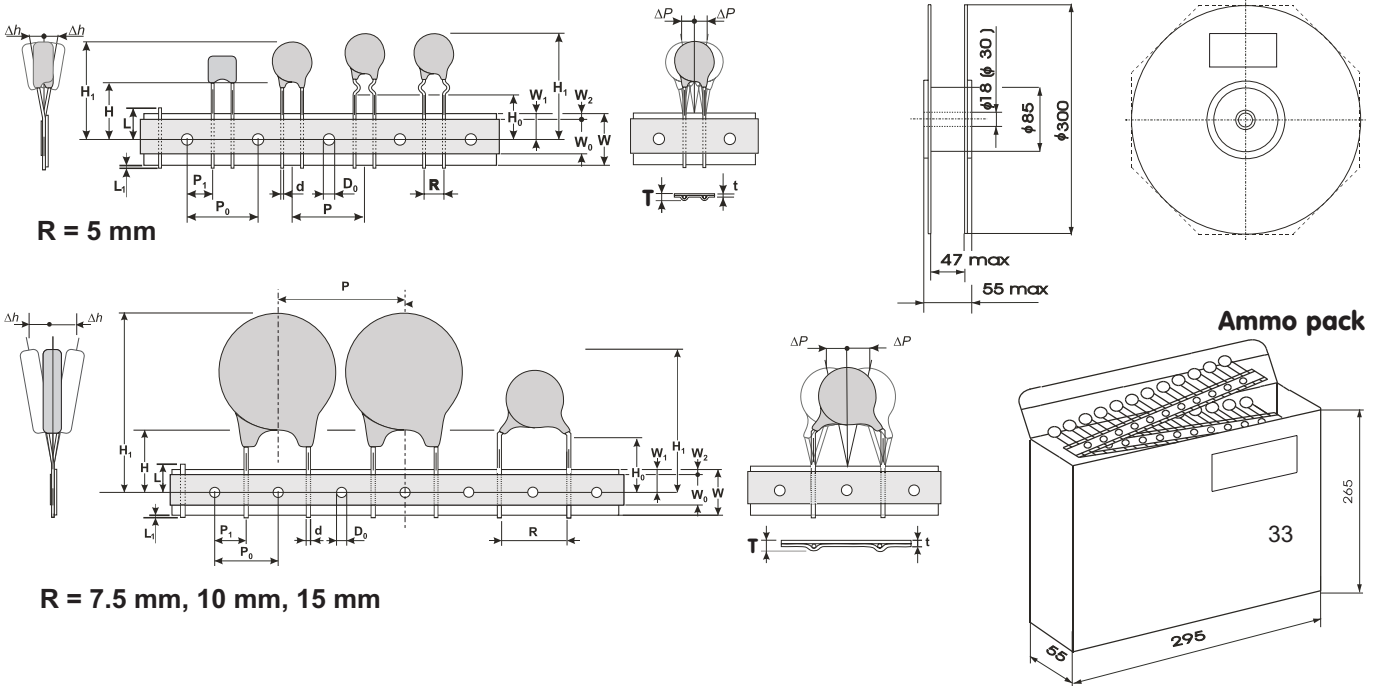

R = 5 mm

R = 7.5 mm, 10 mm, 15 mm

Symbol	Parameter	Model Size			
		R = 5 mm	R = 7.5 mm	R = 10 mm	R = 15 mm
		Dimension (mm)			
W	Carrier tape width	18 +1.0/-0.5	18 +1.0/-0.5	18 +1.0/-0.5	18 +1.0/-0.5
W₀	Hold down tape width	5 min	5 min	5 min	5 min
W₁	Sprocket hole position	9 +0.75/-0.5	9 +0.75/-0.5	9 +0.75/-0.5	9 +0.75/-0.5
W₂	Distance between the upper edges of the carrier tape and hold-down tape	3 max	3 max	3 max	3 max
T	Total tape thickness	1,5 Max	1,7 max	1,9 max	2,1 max
t	Tape thickness	0,9 Max	0,9 Max	0,9 Max	0,9 Max
P	Pitch of component	12.7 ± 1.0	12.7 ± 1.0	25.4 ± 1.0	25.4 ± 1.0
P₀	Feed hole pitch	12.7 ± 0.3	12.7 ± 0.3	12.7 ± 0.3	12.7 ± 0.3
P₁	Feed hole center to pitch	3.85 ± 0.7	8.95 ± 0.7	7.7 ± 0.7	5.2 ± 0.7
R	Lead Spacing	5 +0.5/-0.2	7.5 +0.5/-0.2	10 +0.5/-0.2	15 +0.5/-0.2
ΔP	Component alignment	± 1.3 max	± 1.3 max	± 1.3 max	± 1.3 max
Δh	Component alignment	± 2 max	± 2 max	± 2 max	± 2 max
d	Wire diameter	0.6 max	0.8 max	1 max	1.2 max
D₀	Feed hole diameter	4 ± 0.2	4 ± 0.2	4 ± 0.2	4 ± 0.2
H	Height from tape center to comp. base	18 +2.0/-0.0	18 +2.0/-0.0	18 +2.0/-0.0	18 +2.0/-0.0
H₀	Seating plane height	16 ± 0.5	16 ± 0.5	16 ± 0.5	16 ± 0.5
H₁	Component height	32.2 max	46.5 max	46.5 max	46.5 max
L	Protrusion - cut out	11 max	11 max	11 max	11 max
L₁	Protrusion - cut off	0.5 max	0.5 max	0.5 max	0.5 max

Package units

Series	Package	Dimensions							
		381 and 382	481 and 482	602	802 and 804	962 and 964	144	186	246
CL	Reel/Ammo	3000	2500	2000	2000	/	/	/	/
	Bulk	2000		1500		1000	800	500	200

Reliability Testing Procedures

RFI Suppression and Safety Capacitor Testing according to EN 132 400 and IEC 60384-1.

Reliability Parameter	Test	Tested according to	Condition to be satisfied after testing
Voltage Proof	V_t	EN 132 400, Test 4.2.1. - the voltage shall be raised from near zero to the test voltage V _t at a rate not exceeding 150 V/s, where for : Class X1 Capacitors V _t = 2*V _{rms} + 1500 V~, 1 minute Class Y1 Capacitors V _t = 4000 V~, 1 min Class Y2 Capacitors V _t = 2* V _{rms} + 1500 V~, 1 minute	no permanent breakdown or flash-overs during the test period
Impulse Voltage		EN 132 400, Test 4.13. - 24 impulses of the same polarity shall be applied to the capacitor. The time between impulses shall be no less than 10 s, where for : Class X1 Capacitors V _p = 4 kV Class Y1 Capacitors V _p = 8 kV Class Y2 Capacitors V _p = 5 kV	no self-healing breakdowns or flash-overs
AC/DC Bias Reliability	AC/DC Life Test	EN 132 400, Test 4.14, 1000 h at UCT, where : - for X Class Capacitors : at V = 1,25 V _{rms} and once per hour the voltage shall be increased to 1000 V~ for 0,1 s - for Y Class Capacitors : at V = 1,7 V _{rms} and once per hour the voltage shall be increased to 1000 ~ for 0,1 s	no visible damage ΔC/C < 20 % Δtan δ < 0,008 IR greater than 50 % of the applicable limits no permanent breakdown or flash-over during Voltage proof
Charge and Discharge		EN 132 400, Test 4.15. - 10,000 cycles of charge and discharge at the rate of one operation per minute with the test voltage of SQRT(2) * V _{rms} , discharge rate adjusted to 100 V/μs	ΔC/C < 10 % Δtan δ < 0,008 IR greater than 50 % of the applicable limits
Capacitance - Temperature Characteristics		Measurement of capacitance and tan δ in the temperature chamber at 20 °C and at UCT and LTC	within specification
Radio-Frequency Characteristics		EN 132 400, test 4.16. - measurement of capacitor impedance over a range of frequencies	within specification
Capacitance - Voltage Characteristics		Measurement of capacitance and tan δ at 20 °C with applied rated voltage	within specification
Environmental and Storage Reliability	Climatic Sequence	EN 132 400, Test 4.11. a) Dry heat, 16 h, UCT, Test Ba, IEC 68-2-2 b) Damp heat, cyclic, the first cycle : 55 °C, 93 % RH, 24 h, test Db, IEC 68-2-1 c) Cold, LCT, 2 h, Test Aa, IEC 68-2-1 d) Damp heat cyclic, remaining 5 cycles : 55 °C, 93 % RH, 24 h /cycle, test Bd, IEC 68-2-30	no visible damage ΔC/C < 20 % Δtan δ < 0,008 IR greater than 50 % of the applicable limits no permanent breakdown or flash-over during Voltage proof
	Thermal Shock	EN 132 400, Test 4.6, Test Na, IEC 68-2-14, 5 cycles UCT/LCT, 30 minutes	no visible damage
	Steady State Damp Heat	EN 132 400, Test 4.12, Test Ca, IEC 68-2-3, 56 days, 40 °C, 93 % RH	no visible damage ΔC/C < 20 % Δtan δ < 0,008 IR greater than 50 % of the applicable limits no permanent breakdown or flash-over during Voltage proof
	Storage Test	IEC 68-2-2, Test Ba 1000 h at maximum storage temperature	no visible damage ΔC/C < 20 % Δtanδ < 0,008 IR greater than 50 % of the applicable limits no permanent breakdown of flash-over during voltage proof
Mechanical Reliability	Solderability	EN 132 400, Test 4.5., Test Ta, IEC 68-2-20 , solder bath and reflow method	Solderable at shipment and after 2 years of storage - limits*
	Resistance to Soldering Heat	EN 132 400, Test 4.4., Test Tb, IEC 68-2-20, solder bath and reflow method	no visible damage ΔC/C < 10 %
	Robustness of Termination	EN 132 400, Test 4.3. , Test Ua, IEC 68-2-21	no visible damage
	Vibration	en 132 400, Test 4.7., Test Fc, IEC 68-2-6, Frequency range 10 to 55 Hz Amplitude 0.75 mm or 98 m/s ² Total duration 6 h (3 x 2 h) Waveshape - half sine	no visible damage
	Mechanical Shock	EN 132 400, Test 4.9, Test Ea, IEC 68-2-27 Acceleration = 490 m/s ² , 100 g 6ms and 50 g 11 ms, Waveshape - half sine Number of shocks = 3 x 6	ΔC/C < 10 % tan δ within specification no visible damage

* storage, criteria > 95 % must be covered by solder for reflow meniscus

Protective Device Programme

Leaded Varistors

- AV Series** - Leaded(TH) Automotive Varistors
- ZV Series** - Leaded(TH) Low Voltage Varistors
- CV Series** - Medium Voltage Disc Varistors
- CV+ Series** - Extended Medium Voltage Disc Varistors
- SV Series** - Special Medium Voltage Varistors
 - Standard Types*
 - Full Custom Parameter Designed Types*

High Energy Varistors

- ZOV Series** - Square Shaped High Energy Varistors
 - Standard Types*
 - Full Custom Parameter Designed Types*
 - Stacked High Energy Varistor Blocks*
- ZOVR Series** - Round Shaped High Energy Varistors
- ZOVS Series** - Stacked High Energy Varistors

SMD Varistors

- PV Series** - SMD Plastic Encapsulated Varistors
- DV Series** - Low Profile Medium Voltage SMD Varistors

SMD Varicons

- ZV Series** - SMD Low Voltage Varicons
- ZVE Series** - ESD Suppression Varicons
- ZVX Series** - Low Capacitance & Low Energy Varicons
- AV Series** - SMD Automotive Varicons

Dual Function Varicons

- MV Series** - Dual Function Low Voltage Varicons (SMD and TH)
- OV Series** - Dual Function Automotive Varicons (SMD and TH)

Ceramic Capacitors

- KM Series** - RFI Suppression Capacitors
- KZ Series** - Safety Capacitors
- KV Series** - High Voltage Capacitors
- C Series** - SMD multilayer Capacitors
- CL Series** - Leaded(TH) multilayer Capacitors



SI-8360 Zuzemberk, Grajski trg 15, Slovenia

Phone : (+ 386 7) 3885-120

Fax : (+ 386 7) 3885-158

e-mail : info@keko-varicon.si

home page : <http://www.keko-varicon.si>

All rights reserved / Copyright © 2008 KEKO VARICON d.o.o.