

## MEDIUM VOLTAGE VARICONS® DV SERIES

### Description

DV Series of medium voltage varicons is designed to protect electronic equipment against high voltage surges in the medium voltage region. They offer excellent transient energy absorption due to improved energy volume distribution and power dissipation. Compared to other medium voltage SMD varistors DV Varicons have very low profile.

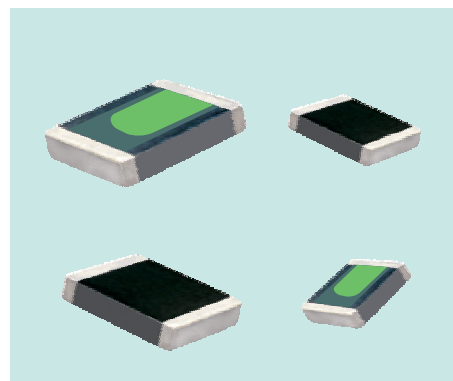

DV varicons are designed for surface mounting and are available in two model sizes. These transient voltage suppressers cover operating voltage  $V_{rms}$  from 11 V to 300 V, featuring maximum surge currents from 400 A to 1200 A.

### Features

- Fully lead-free component
- Operating voltage range  $V_{dc}$  ..... 14 V to 385 V
- Operating voltage  $V_{rms}$  ..... 11 V to 300 V
- 2 Model sizes available ..... 3225 and 4032
- Broad range of current and energy handling capabilities
- Leadless chip form - zero inductance guaranteeing the fastest speed of response to transient surges
- + 125 °C continuous operating temperature
- Insensitive to water cleaning procedures and to humidity corresponding to climatic category 55/125/56
- Dimensional and weight savings on the board - low profile medium voltage SMD varistor
- No packaging improves the flammability rating
- Available in tape and reel for automatic pick and place

### Absolute Maximum Ratings

	Units	Value
<b>Continuous :</b>		
Steady State Applied Voltage :		
DC Voltage Range ( $V_{dc}$ )	V	14 to 385
AC Voltage Range ( $V_{rms}$ )	V	11 to 300
<b>Transient :</b>		
Non-Repetitive Surge Current, 8/20 $\mu$ s Waveform, ( $I_{max}$ )	A	100 to 1200
Non-Repetitive Surge Energy, 10/1000 $\mu$ s Waveform ( $W_{max}$ )	J	0,6 to 30
<b>Operating Ambient Temperature</b>	°C	-55 to +125
<b>Storage Temperature Range</b>	°C	-55 to +150
<b>Threshold Voltage Temperature Coefficient</b>	%/°C	< +0.05
<b>Response Time</b>	ns	< 5
<b>Climatic Category</b>		55 / 125 / 56

**Device Ratings and Characteristics**

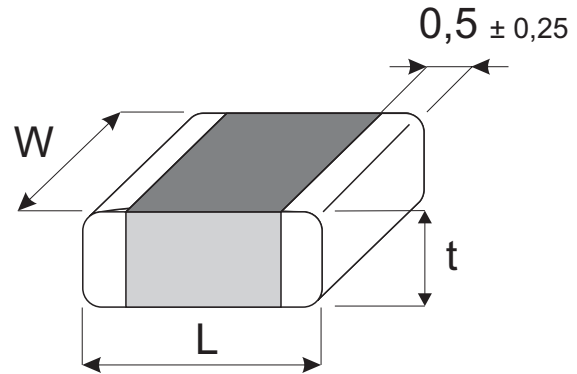

**DV 11 K 3225.....DV 300 K 4032**

Type	V <sub>rms</sub> V	V <sub>dc</sub> V	V <sub>n</sub> @ 1 mA V	V <sub>c</sub> V	I <sub>c</sub> A	W <sub>max</sub> 10/1000 μs J	P max W	I <sub>max</sub> 8/20 μs A	C @ 1 kHz pF	L ± 0,5 mm	W ± 0,4 mm	t max mm
DV 11 K 3225	11	14	18	36	2,5	0,6	0.01	100	2500	8,0	6,3	1,4
DV 11 K 4032	11	14	18	36	5	1,1	0.02	250	4300	10,0	8,0	1,4
DV 14 K 3225	14	18	22	43	2,5	0,7	0.01	100	2200	8,0	6,3	1,6
DV 14 K 4032	14	18	22	43	5	1,3	0.02	250	3500	10,0	8,0	1,6
DV 17 K 3225	17	22	27	53	2,5	0,9	0.01	100	1750	8,0	6,3	1,8
DV 17 K 4032	17	22	27	53	5	1,6	0.02	250	3000	10,0	8,0	1,8
DV 20 K 3225	20	26	33	65	2,5	1,1	0.01	100	1650	8,0	6,3	1,8
DV 20 K 4032	20	26	33	65	5	2,0	0.02	250	2300	10,0	8,0	1,8
DV 25 K 3225	25	31	39	77	2,5	1,2	0.01	100	1500	8,0	6,3	2,0
DV 25 K 4032	25	31	39	77	5	2,4	0.02	250	1900	10,0	8,0	2,0
DV 30 K 3225	30	38	47	93	2,5	1,5	0.01	100	1000	8,0	6,3	2,0
DV 30 K 4032	30	38	47	93	5	2,8	0.02	250	1600	10,0	8,0	2,0
DV 35 K 3225	35	45	56	110	2,5	1,8	0.01	100	800	8,0	6,3	2,0
DV 35 K 4032	35	45	56	110	5	3,4	0.02	250	1400	10,0	8,0	2,0
DV 40 K 3225	40	56	68	135	2,5	2,2	0.01	100	700	8,0	6,3	2,0
DV 40 K 4032	40	56	68	135	5	4,1	0.02	250	1200	10,0	8,0	2,0
DV 50 K 3225	50	65	82	135	5	2,5	0,10	400	400	8,2	6,3	2,0
DV 50 K 4032	50	65	82	135	10	6,5	0,25	1200	580	10,0	8,0	2,0
DV 60 K 3225	60	85	100	165	5	3,0	0,10	400	300	8,2	6,3	2,0
DV 60 K 4032	60	85	100	165	10	7,0	0,25	1200	530	10,0	8,0	2,0
DV 75 K 3225	75	100	120	200	5	4,0	0,10	400	240	8,2	6,3	2,0
DV 75 K 4032	75	100	120	200	10	9,0	0,25	1200	480	10,0	8,0	2,0
DV 95 K 3225	95	125	150	250	5	6,0	0,10	400	210	8,2	6,3	2,0
DV 95 K 4032	95	125	150	250	10	11,0	0,25	1200	310	10,0	8,0	2,0
DV 115 K 3225	115	150	180	300	5	6,5	0,10	400	200	8,2	6,3	2,0
DV 115 K 4032	115	150	180	300	10	13,0	0,25	1200	270	10,0	8,0	2,0
DV 130 K 3225	130	170	205	340	5	7,0	0,10	400	150	8,2	6,3	2,0
DV 130 K 4032	130	170	205	340	10	15,0	0,25	1200	250	10,0	8,0	2,0
DV 140 K 3225	140	180	220	360	5	7,5	0,10	400	180	8,2	6,3	2,0
DV 140 K 4032	140	180	220	360	10	18,0	0,25	1200	240	10,0	8,0	2,0
DV 150 K 3225	150	200	240	395	5	9,0	0,10	400	150	8,2	6,3	2,0
DV 150 K 4032	150	200	240	395	10	18,5	0,25	1200	220	10,0	8,0	2,0
DV 175 K 3225	175	225	270	455	5	9,5	0,10	400	130	8,2	6,3	2,0
DV 175 K 4032	175	225	270	455	10	21,0	0,25	1200	200	10,0	8,0	2,0
DV 230 K 3225	230	300	360	595	5	10,0	0,10	400	110	8,2	6,3	2,0
DV 230 K 4032	230	300	360	595	10	23,0	0,25	1200	170	10,0	8,0	2,0
DV 250 K 3225	250	320	390	650	5	11,0	0,10	400	100	8,2	6,3	2,0
DV 250 K 4032	250	320	390	650	10	25,0	0,25	1200	160	10,0	8,0	2,0
DV 275 K 3225	275	350	430	710	5	13,0	0,10	400	90	8,2	6,3	2,0
DV 275 K 4032	275	350	430	710	10	29,0	0,25	1200	150	10,0	8,0	2,0
DV 300 K 3225	300	385	470	775	5	15,0	0,10	400	85	8,2	6,3	2,0
DV 300 K 4032	300	385	470	775	10	30,0	0,25	1200	140	10,0	8,0	2,0

KEKO VARICON products are sold by description only - product technical specification. KEKO VARICON reserves the right to make changes in circuit design and/or specifications at any time without notice. Accordingly the reader is cautioned to verify that data sheets are current before placing orders. Information furnished by KEKO VARICON is believed to be accurate and reliable. However, no responsibility is assumed by KEKO VARICON for its use; nor for any infringements of patents or other rights of third parties which may result from its use.